

INSTRUCTION MANUAL

ColorPlus 2



Absorption Measuring Instrument

SIGRIST-PHOTOMETER AG
Hofurlistrasse 1
CH-6373 Ennetbürgen
Switzerland

Tel. +41 41 624 54 54
Fax +41 41 624 54 55
info@photometer.com
www.photometer.com

Contents

1	General user information	5
1.1	Terms used in this document (glossary)	5
1.2	Purpose of the Instruction Manual	5
1.3	Target group of the documentation	5
1.4	Additional documentation	5
1.5	Copyright provisions	5
1.6	Document storage location	5
1.7	Order document	6
1.8	Proper use	6
1.9	User requirements	6
1.10	Declaration of conformity	6
1.11	Use restrictions	6
1.12	Dangers when not used properly	7
1.13	Meaning of the safety symbols	8
1.14	Meaning of the pictograms	9
2	Instrument overview	10
2.1	Overview of a water measuring point	10
2.2	Overview of an ozone measuring point	11
2.3	Overview of a chlorine measuring point	12
2.4	Overview of a beverage measuring point	13
2.5	Overview of a measuring point with sliding measuring cell	14
2.6	Overview of a measuring point for the 4 th clarification stage	15
2.7	Designation of the ColorPlus 2	16
2.8	Scope of supply and accessories	17
2.9	Technical data for the ColorPlus 2	22
3	General safety points	26
3.1	Dangers when properly used	26
3.2	Storing the calibration aids	27
3.3	Residual risk	28
3.4	Warning and danger symbols on the instrument	28
3.5	Preventing undesirable online access attempts	29
4	Mounting	30
4.1	Mounting the photometer for a water measuring point	30
4.2	Mounting the photometer on the inline housing	31
4.3	Mounting the photometer with sliding measuring cell	33
4.4	Mounting 4 th clarification stage	33
4.5	Connecting the cooling water (optional)	36
4.6	Mounting customer-specific measuring cells	36
4.7	Mounting the SICON (M)	37
5	Electrical installation	38
5.1	Safety pointers for the electrical connection	38
5.2	Opening the cover on the SICON (M)	39
5.3	Overview of the opened SICON (M) control unit	40
5.4	Connecting the SICON (M)	41
5.5	Electrical connection, 4 th clarification stage	43
5.6	Connecting the field bus interfaces (optional)	44
5.7	Connecting the analog modules (optional)	49
5.8	Connecting the optional 24 VDC power supply	51
6	Commissioning	52
7	Operation	54

- 7.1 Operation basics 54
- 7.2 Control elements in measuring mode 55
- 7.3 Menu button 55
- 7.4 Valu button 55
- 7.5 Info button 56
- 7.6 Diag button 58
- 7.7 Functions of the log screen (Log button) 59
- 7.8 Displays in measuring mode 60
- 7.9 Lock / unlock the touch screen 61
- 7.10 Switching to service mode 62
- 7.11 Control components in service mode 63
- 8 Settings 66
 - 8.1 Setting the operating language 66
 - 8.2 Setting the current outputs 67
 - 8.3 Setting the limits 68
 - 8.4 Setting the outputs 70
 - 8.5 Setting the date and time 71
 - 8.6 Setting or changing the access code 72
 - 8.7 Backup configured data 73
- 9 Servicing 74
 - 9.1 Servicing schedule 75
 - 9.2 Cleaning of the bypass measuring cell 76
 - 9.3 Replacing the measuring cell windows 77
 - 9.4 Replacing or cleaning the measuring cell windows on the VARINLINE® housing 79
 - 9.5 Cleaning or replacing the measuring cell windows on the sliding measuring cell 82
 - 9.6 Cleaning or replacing the windows on the calibration measuring cell 84
 - 9.7 Replacing the desiccant on the transmitter 86
 - 9.8 Replacing the desiccant on the receiver 87
 - 9.9 Recalibrating the photometer 88
 - 9.10 Recalibrating the photometer with sliding measuring cell 89
 - 9.11 Functional check with checking unit 91
 - 9.12 Replacing the UV light source 93
 - 9.13 Changing the battery in the SICON (M) 95
- 10 Troubleshooting 96
 - 10.1 Pinpointing malfunctions 96
 - 10.2 Warning messages and effect on operation 97
 - 10.3 Fault messages and effect on operation 98
 - 10.4 Prioritized fault messages and their effect on operation 100
- 11 Customer service information 101
- 12 Decommissioning/Storage 102
 - 12.1 Decommissioning the photometer 102
 - 12.2 Storing the photometer 103
- 13 Packaging / Transport / Returning 104
- 14 Disposal 105
- 15 Spare parts list 106
- 16 Index 110

1 General user information

1.1 Terms used in this document (glossary)

Please refer to our website for specialist terms: www.photometer.com/en/glossary/

1.2 Purpose of the Instruction Manual

This Instruction Manual provides the user with helpful information about the entire life cycle of the ColorPlus 2 and its peripheral devices. Before commissioning the instrument, you should be completely familiar with the Instruction Manual.

1.3 Target group of the documentation

The Instruction Manual is intended for all persons who are responsible for the operation and maintenance of the instrument.

1.4 Additional documentation

DOC. NO.	TITLE	CONTENT
13047E	Brief Instructions	The most important functions and the servicing schedule.
13046E	Reference Handbook	More sophisticated menu functions and worksteps for advanced users.
13042E	Data Sheet	Descriptions and technical data about the instrument.
13048E	Service Manual	Repair and conversion instructions for service engineers.
13129DEF	Declaration of Conformity	Compliance with the underlying directives and standards.

1.5 Copyright provisions

This document has been written by SIGRIST-PHOTOMETER AG. Copying or modifying the content or giving this document to third parties is permitted only with the express consent of SIGRIST-PHOTOMETER AG.

1.6 Document storage location

This document is part of the product. It should be stored in a safe place and always be close at hand for the user.

1.7 Order document

The most recent version of this document can be downloaded at www.photometer.com (first time registration required).
It can also be ordered from a SIGRIST representative in your country (→ Instruction Manual "Customer service information").

1.8 Proper use

The photometer and its peripherals are designed for measuring the absorption of liquids and gases.

1.9 User requirements

The instrument may be operated only by trained technical personnel who have read and understood the content of the Instruction Manual.

1.10 Declaration of conformity

Current technological principles were followed in designing and manufacturing the instrument. They comply with the applicable guidelines concerning safety and duty to take due care.



EU: The measuring instrument meets all applicable requirements within the European Union (EU) for carrying the CE mark.



Please refer to the separate declaration of conformity for details. Section 1.4

1.11 Use restrictions



**EXPLOSION
HAZARD!**

Operation in an inappropriate environment.

Use in explosive areas can cause explosions, which can lead to the death of persons in the vicinity.

- It is not permitted to operate the instrument in explosion hazardous areas or rooms.
- It is not permitted to use the instrument with explosive sample substances.

1.12 Dangers when not used properly



DANGER!

Operation when not used properly.

Improper use of the instrument can cause injuries to persons, process-related consequential damage and damage to the instrument and its peripherals.

In the following cases the manufacturer cannot guarantee the protection of persons and the instrument and therefore assumes no legal responsibility:

- The instrument is used in a way not included in the described area of application.
- The instrument is not properly mounted, set up or transported.
- The instrument is not installed and operated in accordance with the Instruction Manual.
- The instrument has been operated with accessory parts which SIGRIST-PHOTOMETER AG has not expressly recommended.
- Improper changes to the instrument have been performed.
- The instrument has not been operated within the specifications, in particular concerning pressure and temperature.
- The instrument is exposed to vibrations, shocks or other mechanical forces.

1.13 Meaning of the safety symbols

All **danger symbols** used in this document are explained below:



DANGER!

Danger due to electrical shock that may result in serious bodily injury or death.

Non-observance of this notice may lead to electrical shocks and death.



EXPLOSION HAZARD!

Danger due to explosion that may result in serious bodily injury or death.

Non-observance of this notice may cause explosions resulting in serious property damage and death.



WARNING!

Warning about bodily injury or hazards to health with long-term effects.

Non-observance of this warning may lead to injuries with possible long-term effects.



CAUTION!

Notice about possible material damage.

Non-observance of this notice may cause material damage to the instrument and its peripherals.



DANGEROUS LIQUID

Danger due to acidic or toxic liquids.

Non-observance of this warning can lead to permanent damage to the eyes and skin. Adhere to the following instructions:

	Wear protective goggles.		Wear gloves and safety clothing.
--	--------------------------	--	----------------------------------

1.14 Meaning of the pictograms

All **pictograms** used in this document are explained below:



Additional information about the current topic.



Practical procedures when working with the ColorPlus 2.



Manipulations on the touchscreen.



The screenshot is an example and may differ from current device.

2 Instrument overview

2.1 Overview of a water measuring point

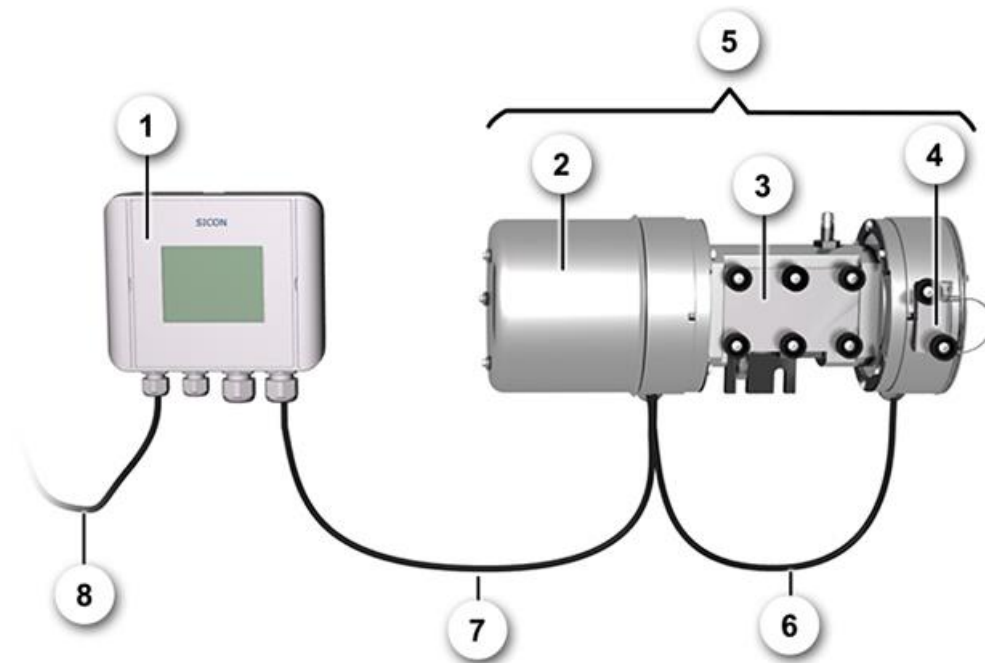

Figure 1: Overview of a water measuring point with PVC measuring cell

①	SICON control unit	②	Transmitter
③	PVC bypass measuring cell 100/50 mm optical path length	④	Receiver with external checking unit
⑤	Photometer with bypass measuring cell, complete	⑥	Connection cable between transmitter and receiver
⑦	Connection cable between photometer and SICON control unit	⑧	Cable for 24 VDC power supply

2.2 Overview of an ozone measuring point

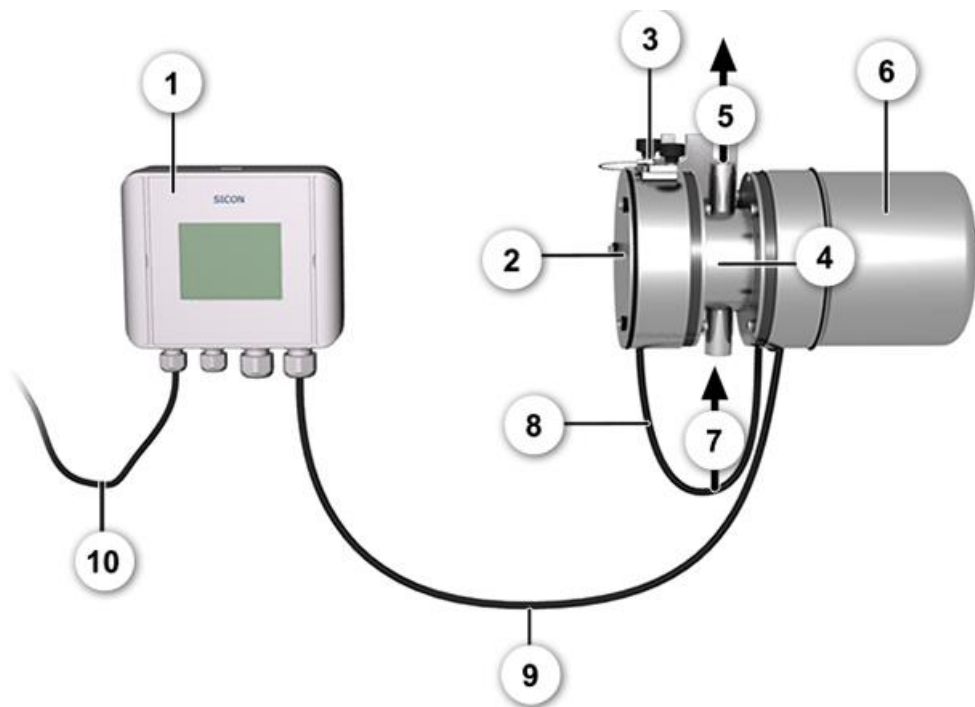

Figure 2: Overview of an ozone measuring point with Stainless steel measuring cell

①	SICON control unit	②	Receiver
③	External checking unit	④	Stainless steel measuring cell
⑤	Measuring cell outlet	⑥	Transmitter
⑦	Measuring cell inlet	⑧	Connection cable between transmitter and receiver
⑨	Connection cable between photometer and SICON control unit	⑩	Cable for 24 VDC power supply

2.3 Overview of a chlorine measuring point

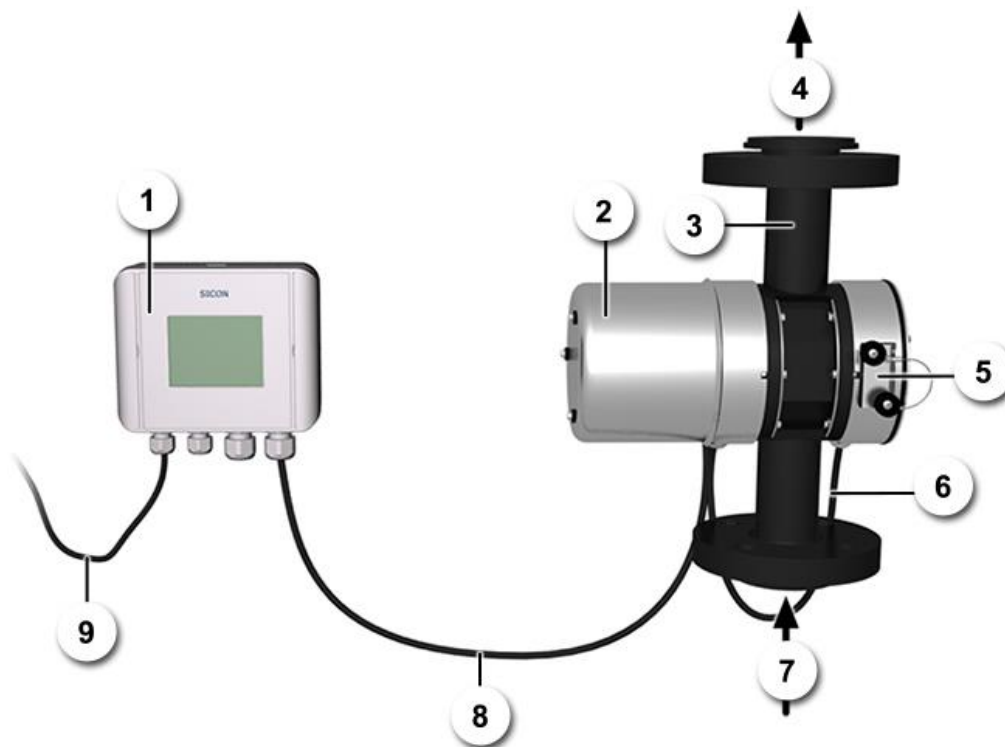

Figure 3: Overview of a chlorine measuring point with PVDF measuring cell

①	SICON control unit	②	Transmitter
③	PVDF measuring cell	④	Measuring cell outlet
⑤	Receiver with external checking unit	⑥	Connection cable between transmitter and receiver
⑦	Measuring cell inlet	⑧	Connection cable between photometer and SICON control unit
⑨	Cable for 24 VDC power supply		

2.4 Overview of a beverage measuring point

The following overview shows the installation of the ColorPlus 2 in a VARINLINE® housing. Installation in a customer-specific measuring cell is made in the same way.

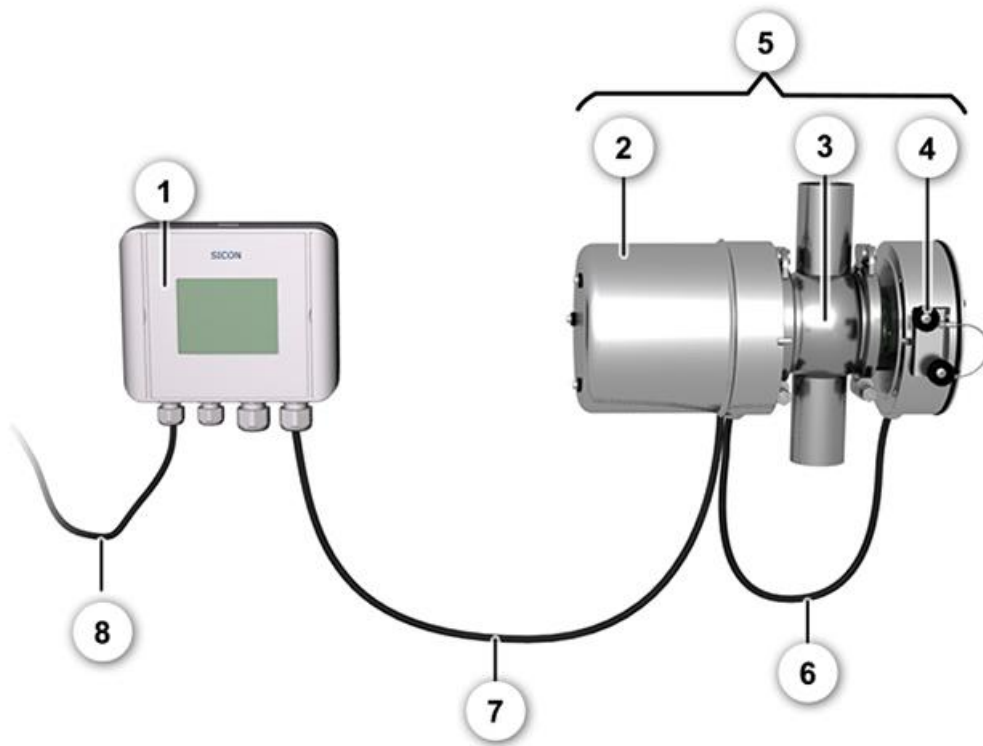

Figure 4: Overview of a beverage measuring point with VARINLINE® housing

①	SICON control unit	②	Transmitter
③	VARINLINE® housing	④	Receiver with external checking unit
⑤	Photometer with VARINLINE® housing	⑥	Connection cable between transmitter and receiver
⑦	Connection cable between photometer and SICON control unit	⑧	Cable for 24 VDC power supply

2.5 Overview of a measuring point with sliding measuring cell

The following overview shows a measuring point with sliding measuring cell. The photometer can be moved from the measurement position for recalibration without having to interrupt the sample flow.

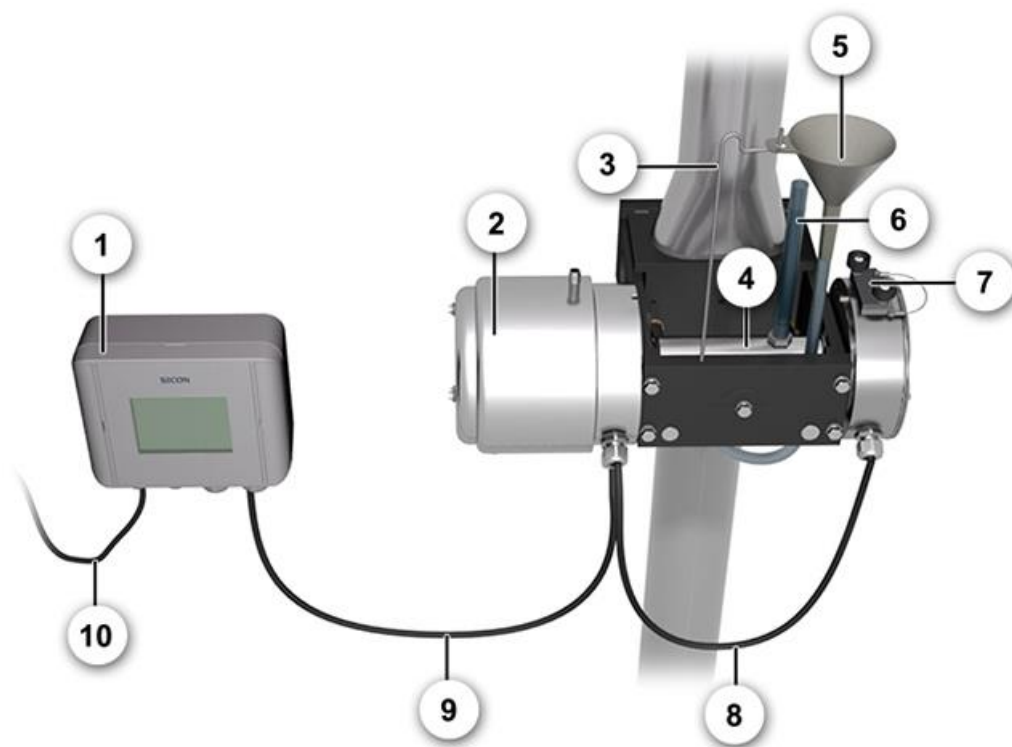

Figure 5: Overview of a measuring point with sliding measuring cell in the adjustment position

①	SICON control unit	②	Transmitter
③	Funnel holder	④	Calibration measuring cell
⑤	Funnel	⑥	Fill level display
⑦	Receiver with external checking unit	⑧	Connection cable between transmitter and receiver
⑨	Connection cable between photometer and SICON control unit	⑩	Cable for 24 VDC power supply

2.6 Overview of a measuring point for the 4th clarification stage

The following overview shows a standard measuring point for the 4th clarification stage:

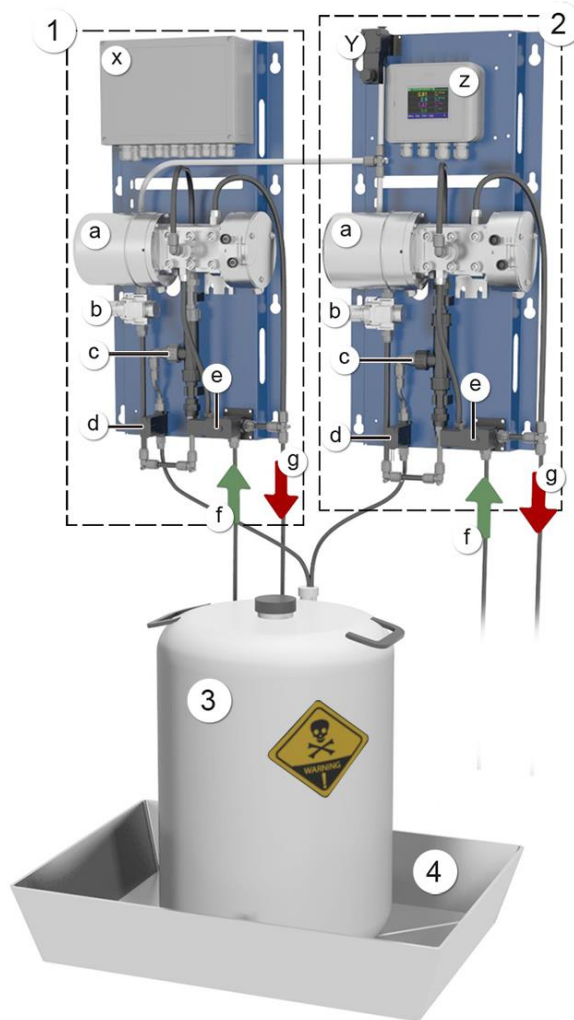

Figure 6: Overview of a measuring point for the 4th clarification stage

<p>①</p>	<p>Pre-treatment: a: ColorPlus 2 with PVC measuring cell b: Compressed air control valve c: Jet pump d: Cleaning agent valve e: Sample feed valve f: Sample feed g: Sample drain x: Powerbox</p>	<p>②</p>	<p>Post-treatment: a: ColorPlus 2 with PVC measuring cell b: Compressed air control valve c: Jet pump d: Cleaning agent valve e: Sample feed valve f: Sample feed g: Sample drain y: Compressed air valve (compressed air connection) z: SICON M</p>
<p>③</p>	<p>Cleaning agent container (acid tank)</p>	<p>④</p>	<p>Collecting basin</p>

2.7 Designation of the ColorPlus 2

The SICON control unit and ColorPlus 2 photometer are each fitted with a rating plate:

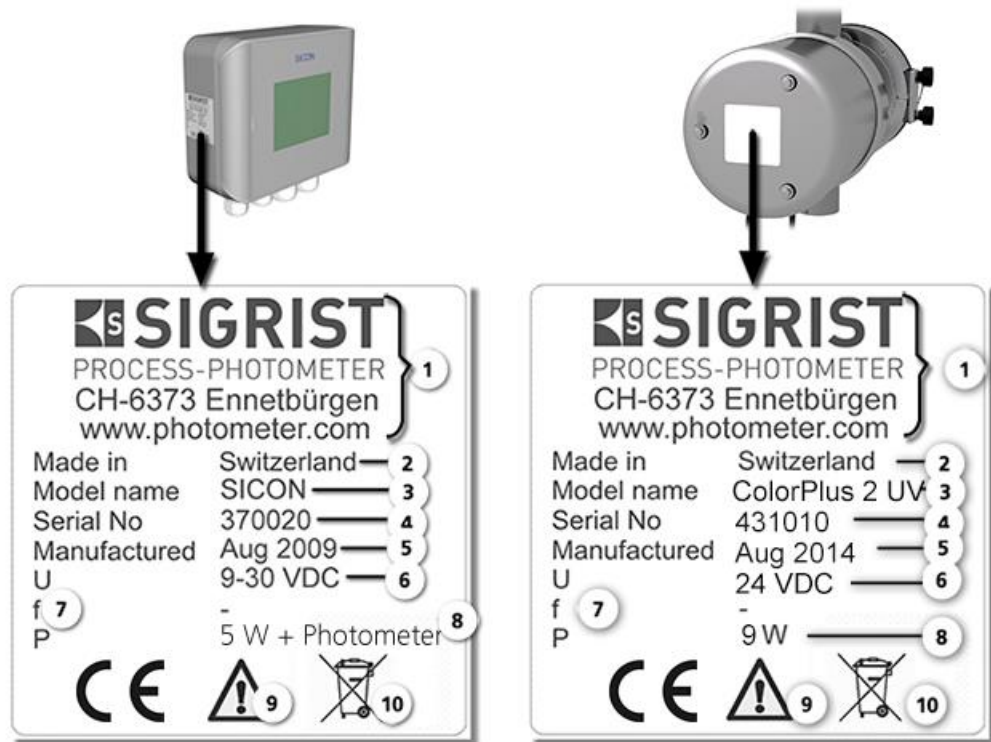
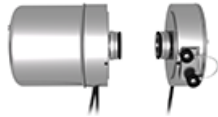









Figure 7: Rating plates on the instruments

①	Manufacturer	②	Country of origin
③	Product name	④	Serial number
⑤	Date of manufacture	⑥	Service voltage
⑦	Frequency range	⑧	Power
⑨	Observe the Instruction Manual	⑩	Observe the disposal information

2.8 Scope of supply and accessories

2.8.1 Standard scope of supply for the ColorPlus 2





PCS.	ART. NO.	NAME	VIEW	VARIANT
1	See the website	ColorPlus 2		ColorPlus 2 for water, ozone and beverages, or as customer-specific version
1	118342	SICON: Control unit 24VDC		
1	119040	SICON M: Multi-channel control unit 24VDC		
1	118404 (VIS) 118407 (UV)	PVC measuring cell (water), 100 mm optical path length		* With hex key for 32 mm window screw connection 
1	119065 (VIS) 119066 (UV)	PVC measuring cell (water), 50 mm optical path length		* 32 mm
1	See the website	VARINLINE® housing (beverages)		Delivered with OPL bit wrench 
1	See the website	VA measuring cell (ozone)		* 32 mm
1	On request	Sliding measuring cell (inline or bypass)		* 32 mm







PCS.	ART. NO.	NAME	VIEW	VARIANT
1	On request	PVDF measuring cell (for hazardous samples)		* 32 mm
1	117853 (VIS) 117854 (UV)	Checking unit		With 1% filter

Documentation:





PCS.	ART. NO.	NAME	VIEW	VARIANT
1	20012	Instruction Manual		German French English
1	20012	Reference Hand-book		German English
1	20012	Brief Instructions		German French English

2.8.2 Optional accessories

PCS.	ART. NO.	NAME	VIEW	VARIANT
1	118442	Profibus DP, interfaces pcb		For SICON (M) only
1	118445	Modbus RTU, interfaces pcb		For SICON (M) only
1	121121	Profinet IO, interfaces pcb		For SICON (M) only
1	119796	HART module		For SICON (M) only
1	119130	4-way current output		For SICON (M) only

PCS.	ART. NO.	NAME	VIEW	VARIANT
1	119795	4-way current input		For SICON (M) only
1	On request	Calibration measuring cell		For sliding measuring cell
1	See the website	Additional checking units with filter values of 80%, 50%, 20%, 10% and 3%		
1	119045	24 VDC mains device		20 W, IP66, input 100 to 240 VAC
1	109534	Connection box		
1	114853	Cooling system		
1	115551	Terminal box for pressure and temperature compensation		

2.8.3 Standard scope of supply for the ColorPlus 2, 4th clarification stage

PCS.	ART. NO.	NAME	VIEW	VARIANT
1	121800	4 th clarification stage with two ColorPlus 2, Powerbox and SICON M		* With hex key for 32 mm window screw connection 
2	117854	Checking unit		With 1% filter
1	121764	Collecting basin 725 x 525 x 235		For basic configuration and expansion to four instruments
1	121763	Acid tank (cleaning agent) 50 l (ø 400 mm)		For basic configuration and expansion to four instruments
2	121745	PE pipe D = 10 mm, L = 2 m		For sample drainage
2	120992	PE pipe D = 8 mm, L = 2 m		For cleaning agent feed
1	121765	Drum funnel		For basic configuration and expansion to four instruments

2.8.4 Optional accessories for the ColorPlus 2, 4th clarification stage

PCS.	ART. NO.	NAME	VIEW	VARIANT
1	See the website	Additional checking units with filter values of 80%, 50%, 20%, 10 % and 3 %		
1	121300	Expansion to three ColorPlus 2 instruments, including cleaning and Conn-P		Can only be operated in combination with the basic configuration.
1	121516	Expansion to four ColorPlus 2 instruments, including cleaning, 24 VDC mains device, with additional collection basin and acid tank		Can only be operated in combination with the basic configuration and third ColorPlus 2.

2.9 Technical data for the ColorPlus 2

2.9.1 Technical data ColorPlus 2

Absorption measurement	Values	
Measuring principle	Absorption	
Measuring span	0 .. 0.1 E to 0 .. 3 E	
Measuring ranges	8, freely configurable	
Wavelength	1 .. 3 different wavelengths at: 254, 313 or 365 .. 700 nm, 760 nm, 340 nm, 280 nm	
Resolution	0.001 E	
Reproducibility	Extinction	Tolerance
	0 .. 1 E	± 2 % of meas value, > 0,001 E
	1 .. 2 E	± 3 % of meas value
	2 .. 3 E	± 4 % of meas value
Linearity	Better than ± 0.5% transmission	
Service voltage	UV: 24 VDC VIS: 9 .. 30 VDC	
Power consumption	UV: 9W (only photometer) VIS: 4W (only photometer)	

Photometer	Values
Dimensions	See detailed dimension drawing
Weight	Depending on version approx. 4 – 4.3 kg (flow cell not included)
Protection class	IP 65
Ambient temperature	<p>-20 .. 50 °C at higher medium temperatures, cooling is possibly required</p> <p>Maximum medium temperature Tm as a function of the ambient temperature Ta:</p> <p>Tm/°C: Medium temperature in °C, Ta/°C: Ambient temperature in °C, VIS: Photometer with LED (visible) lightsources (Version VIS), UV: Photometer with UV lightsources (Version UV)</p>
Ambient humidity	0 .. 100% rel.
Photometer material	Stainless steel 1.4301

Measuring/flow cell	Values
Flow cell for water (bypass flowcell):	<ul style="list-style-type: none"> ▪ PVC housing with hose nipple (Ø outside = 9mm) ▪ max. sample temperature: 50°C ▪ max. sample pressure: 600 kPa (6 bar) ▪ Flow rate: 0.5 .. 1.0 lt/min
Flow cell for ozone (O ₃)	<ul style="list-style-type: none"> ▪ Housing of stainless steel 1.4435 (316L) ▪ max. sample temperature: 60°C ▪ max. sample pressure: 250 kPa (2.5 bar) ▪ Flow rate: 0.5 .. 1.0 lt/min
Flow cell for other liquids (inline flow cell):	VARINLINE® housing of stainless steel 1.4404, DN 40 – 150.
Sliding measuring cell (inline flow cell):	Material specific to customer requirements → specification sheet
User specific (inline flow cell):	Titanium, Hastelloy, PVDF etc.

SICON control unit	Values
Service voltage and power consumption	<ul style="list-style-type: none"> ▪ 9 .. 30 VDC with VIS version ▪ 24 VDC with UV version ▪ 5 W only SICON control unit
Display	<p>¼ VGA with touchscreen Resolution: 320 x 240 pixels with 3.5" diagonal</p>
Outputs / Inputs	<p>Outputs:</p> <ul style="list-style-type: none"> ▪ 4 x 0/4 .. 20 mA, galvanically isolated up to max. 50 V relative to ground and max. 500 Ω burden. ▪ 7 x digital outputs up to max. 30 VDC, freely configurable, 1 output as de-energized closed relay. <p>Inputs:</p> <ul style="list-style-type: none"> ▪ 5 x digital inputs up to max. 30 VDC, freely configurable.
Digital and analog interfaces	Ethernet, microSD-card (for logging, SW-update, diagnostics), Modbus TCP. Optional: Modbus RTU, Profibus-DP or HART, Current output 4-way module and Current input 4-way module
Protection class	IP66
Weight	Approx. 0.6 kg
Dimensions	160 x 157 x 60 mm
Housing material	ABS

Power supply SP-C039	Values
Service voltage	100 .. 240 VAC, 47 .. 63 Hz
Power consumption	Max. 25 W (while the power consumption of the connected sensors must not exceed a value of 21W)
Maximum operating altitude	2,000 m (6,600 ft) above sea level
Protection class	IP 66
Weight	0.7 kg
Dimension	Approx. 130 x 155 x 55 mm
Housing material	PC

2.9.2 Technical data for the ColorPlus 2, 4th clarification stage

Data	Values
Measuring principle	Absorption
Measuring scope	0 .. 3 E
Measuring ranges	8, freely configurable
Wavelength	254 nm
Resolution	0.001 E
Service voltage	100 .. 240 VAC, 47 .. 63 Hz
Power consumption	70 W peak power, 35 W continuous power (105 W peak power, 45 W continuous power with three ColorPlus instruments, 130 W peak power, 65 W continuous power with four ColorPlus instruments)
Protection class	IP65
Measuring cell for water (bypass measuring cell)	<ul style="list-style-type: none"> ▪ PVC housing ▪ Max. medium temperature: 40 °C ▪ Max. medium pressure: 400 kPa (4 bar) ▪ Flow rate: min. 1 l/min
Compressed air connection	2 .. 3.5 bar, Class 563 according to ISO 8573-1

3 General safety points

3.1 Dangers when properly used



DANGER!

Damaged instrument or cabling.

Touching damaged cables may lead to electrical shocks or death.

- The instrument may be operated only when the cables are undamaged.
- The instrument may be operated only if it has been properly installed or repaired.



DANGER!

Dangerous voltage inside the instrument.

Touching live components inside the instrument may lead to electric shocks resulting in death.

- The instrument must not be operated when the housing is removed or opened.



DANGER!

Dangerous UV radiation inside the instrument (UV instruments).

During operation, there is dangerous UV radiation inside the instrument that can cause eye damage.

- The instrument must not be operated when the housing is removed.



DANGER!

Damage to the instrument due to incorrect service voltage.

If the instrument is connected to an incorrect service voltage, the instrument can be damaged.

- The instrument may be connected only to voltage sources as specified on the rating plate.



DANGER!

Missing Instruction Manual after the instrument changes hands.

Operating the instrument without knowledge of the Instruction Manual may lead to injuries to persons and damage to the instrument.

- If the instrument changes hands, always include the Instruction Manual.
- If the Instruction Manual is lost, you can request a replacement.
Registered users can download the current version at www.photometer.com.



CAUTION!

Escaping liquid from leaks on the instrument.

Escaping liquid can lead to flooding of the room and material damage to the building and fittings.

- Check that there are no leaks on a regular basis.



CAUTION!

Penetration of moisture as well as condensation on the electrical components during operation.

If moisture enters the instrument, the ColorPlus 2 can be damaged.

- The USB interface cover must always be attached during operation.
- If the instrument is operated with a water temperature which is lower than the ambient temperature, the instrument must remain switched on.

**CAUTION!****Penetration of moisture as well as condensation on the electrical components during servicing duty.**

If moisture enters the instrument, the ColorPlus 2 can be damaged.

- Work inside the instrument may be performed only in a dry room and at room temperature. The instrument should be at operating or room temperature (avoid condensation on optical and electrical surfaces).

**CAUTION!****The use of aggressive chemicals when cleaning.**

Use of aggressive chemicals can cause damage to instrument components.

- Do not use aggressive chemicals or cleaning agents when cleaning.
- Should the instrument come in contact with aggressive chemicals, clean it thoroughly with a neutral cleaning agent.

3.2 Storing the calibration aids

3.2.1 Checking unit

**WARNING!****Incorrect measurement following the use of a defective checking unit for recalibration.**

The supplied checking unit has been adapted to the instrument. If a defective checking unit is used for recalibration, the measuring accuracy of the instrument may be affected. If recalibration cannot be made due to the loss of the checking unit, the measuring accuracy of the instrument also cannot be guaranteed.

- A subsequently purchased checking unit is always delivered without values and first has to be calibrated to a serviced instrument.
- Store the checking unit in a protected, defined location.

3.2.2 Calibration solutions

**WARNING!****Incorrect measurement following the use of an incorrect or expired calibration solution for recalibration.**

If an incorrect or expired calibration solution is used for recalibration, the measuring accuracy of the instrument may be affected. If recalibration cannot be made due to the loss of the calibration solutions, the measuring accuracy of the instrument also cannot be guaranteed.

- Always ensure that the correct calibration solution is used (e.g. pH 4).
- Pay attention to the indicated expiry date and order a new calibration solution in good time.
- Always store the calibration solution according to the prescribed storage conditions (in a dark place at room temperature).
- Store the calibration solution in a defined location.

3.3 Residual risk



WARNING!

According to the risk assessment of the applied safety directive DIN EN 61010-1, there remains the risk of the displayed measuring values being incorrect. This risk can be reduced with the following measures:

- Use an access code to prevent unauthorized persons from changing parameters.
- Perform the specified servicing duties.

3.4 Warning and danger symbols on the instrument



WARNING!

There are no warning or danger symbols on the instrument.

Users must ensure that they observe the safety measures as specified in the Instruction Manual at all times when working with the instrument and its peripheral equipment, even if no warning or danger symbols are attached to the instrument.

The following sections must be internalized:

- Section 1.8
- Section 1.11
- Section 1.12
- Section 3.1
- Section 3.3
- Observe safety pointers when performing the described procedures.
- Observe local safety pointers.

3.5 Preventing undesirable online access attempts

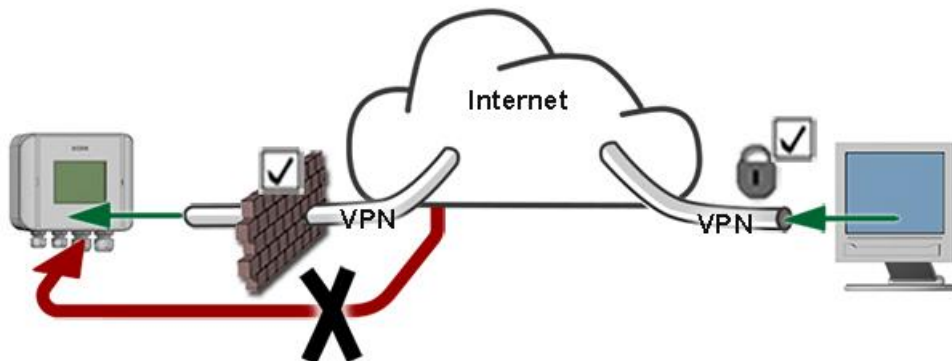

WARNING!

SIGRIST instruments are equipped with an integrated web user interface and Modbus TCP interface, thus offering state-of-the-art administration and control possibilities. However, if these are connected directly to the Internet, then any Internet user can in principle access your instrument and change the configuration.

Please note the following points to prevent this:

- Never connect the instrument directly to the Internet.
- Operate it behind a firewall and block access to the instrument.
- Only connect to branch offices via VPN.
- Change the standard password on commissioning.
- Always keep up to date with the latest changes regarding Internet security so that you can react promptly in the event of alterations.
- Install the latest updates immediately (also for the router and firewall).

4 Mounting

4.1 Mounting the photometer for a water measuring point

The photometer must be installed horizontally. The water outlet must be positioned at the top so that the measuring cell can be well ventilated.



	WORKSTEP	ADDITIONAL INFO / IMAGES
1.	<p>Install the photometer onto a wall using two screws on the fastening plate (A). The transmitter (B) must be finally positioned on the left and the receiver (C) on the right.</p> <p>i A regulator valve should be installed on the sample outlet (E) so that counter pressure can be generated (operation of the measuring cell under pressure so that disruptive air bubbles are eliminated).</p>	<p>The diagram shows a horizontal photometer with a transmitter (B) on the left and a receiver (C) on the right. A fastening plate (A) is located at the bottom center. A sample inlet (D) is on the left side, and a sample outlet (E) is on the top center. Two cables are connected to the bottom of the device.</p>
2.	<p>Connect the sample inlet and sample outlet.</p> <p>D: Sample inlet E: Sample outlet</p>	

4.2 Mounting the photometer on the inline housing

4.2.1 Mounting position of the photometer in the inline housing

Using a standardized inline housing (VARINLINE® or compatible models), the photometer can be installed in both horizontal and vertical product lines.

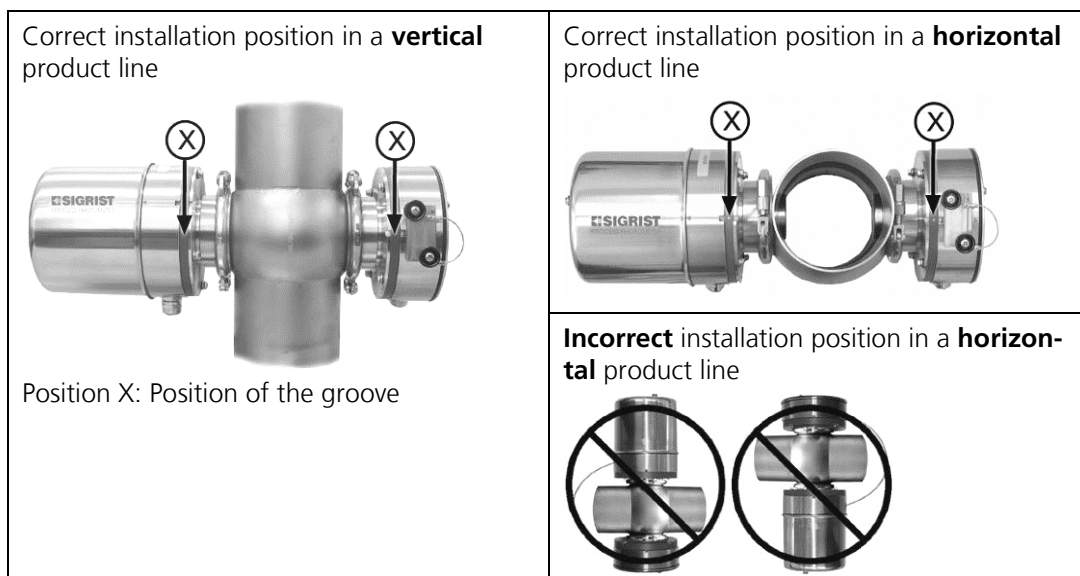

The following points must be observed here:

- The groove (X) on the transmitter and receiver must face forwards when mounted.
- Always mount the photometer so that the transmitter and receiver are horizontally opposite one another. Accordingly, only install in a housing where this layout is possible.
- The photometer must be mounted in the line at least 2 meters away from inspection glasses and other unwanted light sources.

4.2.2 Mounting the photometer on the inline housing

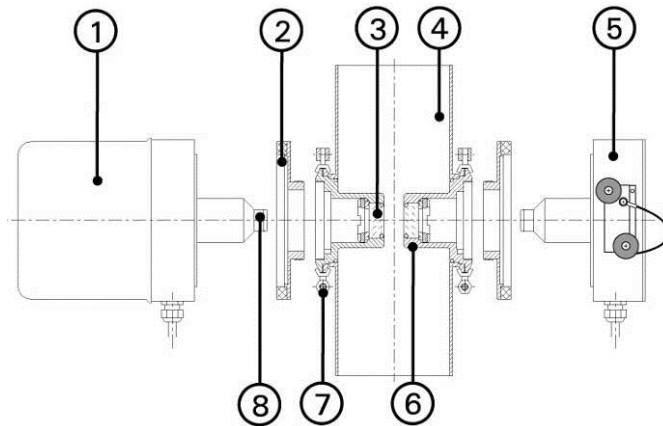

Figure 8 : Cross-section of ColorPlus 2

①	Transmitter	②	Ring adapter
③	Measuring cell window	④	Inline housing
⑤	Receiver with external checking unit	⑥	OPL bit
⑦	Lock ring	⑧	Flood protection

The ColorPlus 2 is delivered with an OPL bit (Figure 8, pos. 6) on both sides for installation in an inline housing. The OPL bits with measuring cell window (Figure 8, pos. 3), the corresponding flood protection (Figure 8, pos. 8) and ring adapter (Figure 8, pos. 2) are already installed according to customer requirements at the factory.



	WORKSTEP	ADDITIONAL INFO / IMAGES
1.	Insert the complete transmitter/receiver into the mounting on the inline housing. i The groove (X) on the transmitter and receiver must face forwards when mounted.	
2.	Loosely position the transmitter/receiver on the inline housing with the lock ring (Figure 8, pos. 7) and tighten with the nut (A).	

4.3 Mounting the photometer with sliding measuring cell

The following points must be observed for mounting a photometer with sliding measuring cell:

- The photometer with sliding measuring cell may only be installed in vertical sample lines.
- Allow sufficient room for maneuver for the sliding measuring cell (operating and checking position).

Please note the corresponding drawing for mounting the sliding measuring cell.

4.4 Mounting 4th clarification stage

4.4.1 Location selection

Note the following points for the operating location:

- The electrical supply must be ensured.
- The water supply must be ensured as described in the technical data.
- The compressed air connection must be ensured as described in the technical data (Section 2.9.2).
- The drainage of water must be possible without obstructions.
- The system should not be exposed to direct sunlight during measurement as the measurement can be skewed by excessive external light.

4.4.2 Mounting the units for the 4th clarification stage

Observe the **COLORPLUS-4KL-MB** dimension sheet when mounting the 4th clarification stage.



Only lift units for the 4th clarification stage on the blue base plate.



	WORKSTEP	ADDITIONAL INFO / IMAGES
1.	Drill four holes in the wall for the threaded anchors according to the supplied drill template.  Preferably, use M6 threaded anchors for fastening units for the 4 th clarification stage. The threaded anchors should project 2 or maximum 3 cm from the wall.	
2.	Fasten the threaded anchors in the wall.	
3.	Fasten the corresponding unit of the 4 th clarification stage on the threaded anchors.	

4.4.3 Connecting the sample feed and compressed air



DANGEROUS LIQUID

Danger due to acidic or toxic liquids.

Non-observance of this warning can lead to permanent damage to the eyes and skin. Adhere to the following instructions:



Wear protective goggles.







Wear gloves and safety clothing.

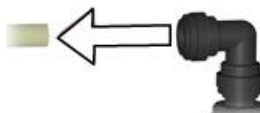

	WORKSTEP	ADDITIONAL INFO / IMAGES
1.	Connect the sample supply to the sample feed valve (arrows). Carry out this procedure for pre-treatment and post-treatment (Section 2.6).	
2.	Connect the compressed air to the compressed air valve (arrow).	
3.	Mount the junction hose for compressed air (arrow).	

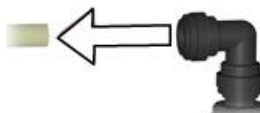
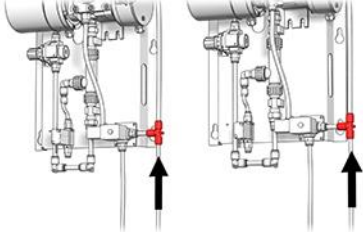

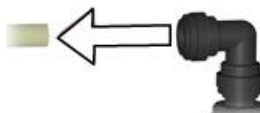
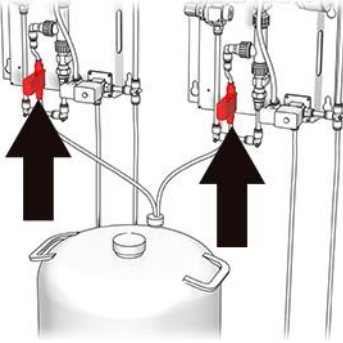
	WORKSTEP	ADDITIONAL INFO / IMAGES		
4.	<p>Mount the sample drain (arrows) and fasten in place. Carry out this procedure for pre-treatment and post-treatment (Section 2.6).</p> <p>⚠ Injuries to the eyes and skin due to the uncontrolled release of cleaning agent into the surrounding area. As acidic solutions are used in the cleaning process, it is recommended to fasten the outlet hose in place so that no cleaning agent can escape into the surrounding area.</p> <p>i The hoses can be removed (1) or fastened (2) as follows:</p> <table border="1" data-bbox="440 817 1007 1025"> <tr> <td data-bbox="440 817 722 1025"> 1a: Push in the hose coupling.  </td> <td data-bbox="722 817 1007 1025"> 1b: Pull the hose out of the coupling.  </td> </tr> </table> <p>2: Insert the hose into the coupling and engage by applying a little pressure.</p>	1a: Push in the hose coupling. 	1b: Pull the hose out of the coupling. 	
1a: Push in the hose coupling. 	1b: Pull the hose out of the coupling. 			
5.	<p>Place the acid tank into the collecting basin and position it underneath the unit (Section 2.6).</p>			
6.	<p>Fasten the cleaning agent and feed hose to the corresponding valve (arrows) and then insert it into the cleaning agent container. Carry out this procedure for pre-treatment and post-treatment (Section 2.6).</p> <p>⚠ Injuries to the eyes and skin due to the uncontrolled release of cleaning agent into the surrounding area. As acidic solutions are used in the cleaning process, it is recommended to fasten the outlet hose in place so that no cleaning agent can escape into the surrounding area.</p>			

4.5 Connecting the cooling water (optional)

The photometer must be equipped with a cooling system.





	WORKSTEP	ADDITIONAL INFO / IMAGES
	<p>Connect the inlet (A) and outlet (B) to a water circuit.</p> <p>Conventional silicone hoses for nipple diameters of 9.5 mm can be used here.</p> <p>i Ensure that the cooling water flows from bottom to top. There must therefore be sufficient pressure available to ensure the necessary flow of at least 0.2 l/min.</p>	

4.6 Mounting customer-specific measuring cells

Please note the corresponding drawing for mounting customer-specific measuring cells.

4.7 Mounting the SICON (M)



	WORKSTEP	ADDITIONAL INFO / IMAGES
1.	Open the shutters.	
2.	Fasten the control unit to the wall using four screws (circles).	

5 Electrical installation

5.1 Safety pointers for the electrical connection



DANGER!

Connecting the service voltage.

Improper connection of the service voltage can be potentially fatal. The system may also be damaged. Local regulations for electrical connection must be observed at all times.

Further, the following basic principles must be observed:

- Because the system has no main switch, a suitable disconnection device (switch, plug) should be installed near the service voltage. It must be designated and easily accessible.
- It is imperative that the protective conductor is connected.
- The system must not be charged with voltage until the installation is completed and all covers are mounted.
- On systems with a service voltage of between 100 and 240 VAC, a back-up fuse with a max. tripping current of 16 A must be present. The cables must be able to withstand this load.
- If faults cannot be remedied, the system must be put out of operation and protected against inadvertent operation.
- On UV instruments, the supply voltage is 24 VDC.

5.2 Opening the cover on the SICON (M)



	WORKSTEP	ADDITIONAL INFO / IMAGES
1.	Open the shutters.	
2.	Loosen the fastening screws on the cover.	
3.	Open the cover.	
4.	Fasten the cover with the cover clamp. To do this, remove the cover clamp from the park position (X) and fasten the cover in position (Y).	

5.3 Overview of the opened SICON (M) control unit

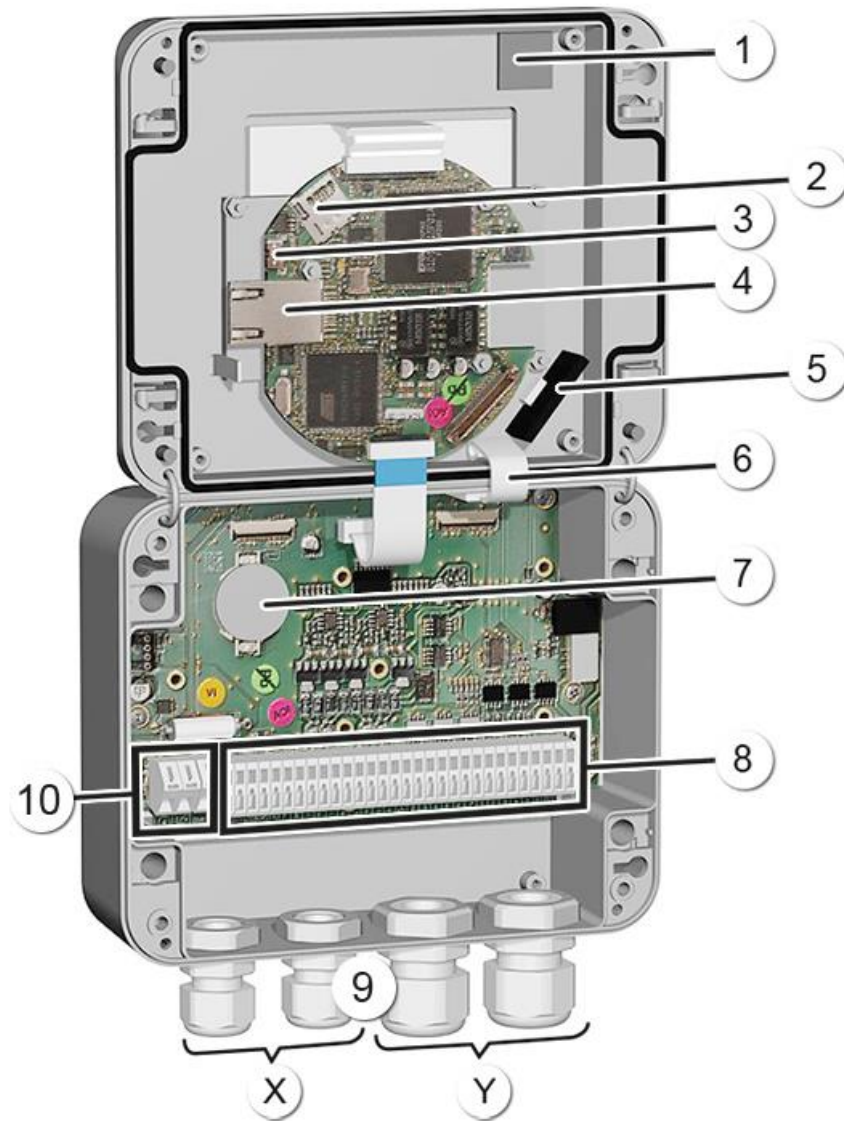

Figure 9: Overview of SICON (M)

①	Park position for cover clamp	②	microSD card (card for log data)
③	USB connection	④	Ethernet connection
⑤	SD card adapter with holder	⑥	Cover clamp in holding position
⑦	Battery	⑧	External connections
⑨	Cable glands X: 4 .. 8 mm Y: 8 .. 13 mm	⑩	Connections for the service voltage 9 .. 30 VDC

5.4 Connecting the SICON (M)



DANGER!

Life-threatening voltage inside the instrument.

Connecting electrical lines can be extremely dangerous. Instrument parts may also be damaged. Local regulations for electrical installations must be observed at all times.

5.4.1 Cable cross-sections over longer distances

- For connections longer than the standard cable length of 5 meters, an optional junction box must be connected between the photometer and control unit.
- Depending on the cable used (cross-section) and power supply, the distance between the control unit and the photometer can be calculated according to the table below.
- For cable lengths of more than 5 meters, shielded cable must be used.

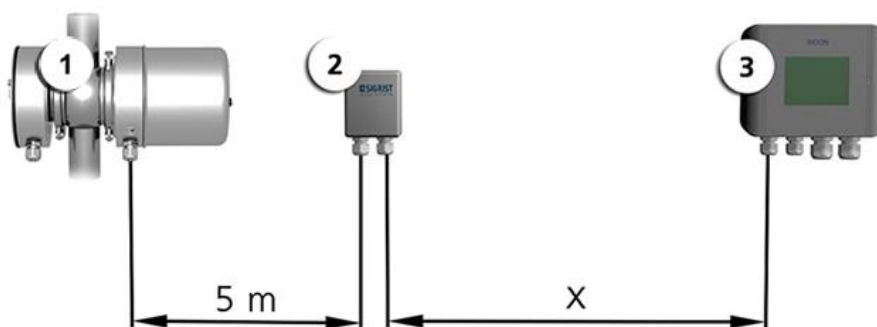

Figure 10: Arrangement of control units at distances of more than 5 meters

①	Photometer	②	Junction box
③	Control unit		

The maximum distance (X) between the control unit and junction box depends on the voltage in the SICON and the cable cross-section used:

Cable cross-section	Max. distance for UV instrument	Max. distance for VIS instrument	Remarks
[mm ²]	[m]	[m]	
0.14	20	60	
0.25	35	100	
0.34	50	140	
0.50	70	210	Standard version
0.75	100	320	
1.00	140	410	
1.50	200	590	

5.4.2 Terminal layout on the SICON

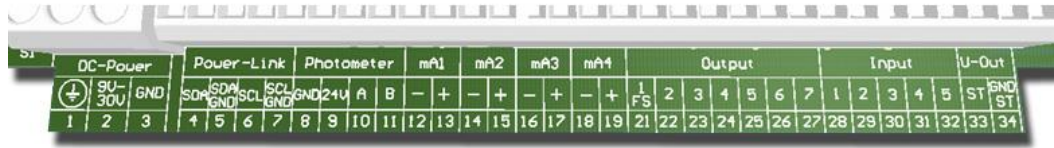
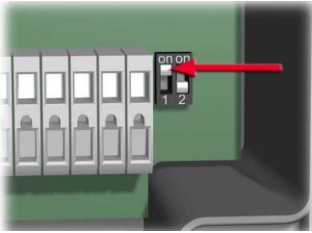

Figure 11: SICON terminal block

Establish the electrical connections in the following sequence:



	TERMINAL	MEANING	REMARKS		
1.	8 .. 11	Connection to the photometer	Terminal	Description	Color
			8	GND (ground)	Green
			9	24 V	Brown
			10	A	White
	11	B	Yellow		
2.	4 .. 7	Connection of external expansion modules (optional)			
3.	12 .. 19	Curr. outputs 1 .. 4	Maximum loop resistance 500 Ohm.		
4.	21 .. 27	Digital optocoupler outputs	Terminal	Description	
			21	Closed de-energized	
			22 .. 27	Open de-energized	
5.	28 .. 32	Digital inputs			
6.	33 .. 34	Internal power supply for operating signals	DIL switch (1) must be ON.		
			 → Reference Handbook		
7.	1 .. 3	Service voltage	UV: 24 VDC ±10 % VIS: 9 .. 30 VDC		



The use of operating signals is described in the Reference Handbook.

5.4.3 Terminal layout on the junction box

The terminals in the junction box are assigned as follows:

CONNECTION FOR PHOTOMETER		CONNECTION FOR CONTROL UNIT	
Terminal	Cable	Terminal	Cable
Blue	Green	Blue	Green
Orange	Brown	Orange	Brown
Dark gray	White	Dark gray	White
Light gray	Yellow	Light gray	Yellow

5.5 Electrical connection, 4th clarification stage



Consult the Instruction Manual for SICON M (document no. 11775) for the electrical connection of the 4th clarification stage.

5.6 Connecting the field bus interfaces (optional)



Information on commissioning the field bus interfaces can be found in the Reference Handbook.

5.6.1 Overview of Profibus DP and Modbus RTU

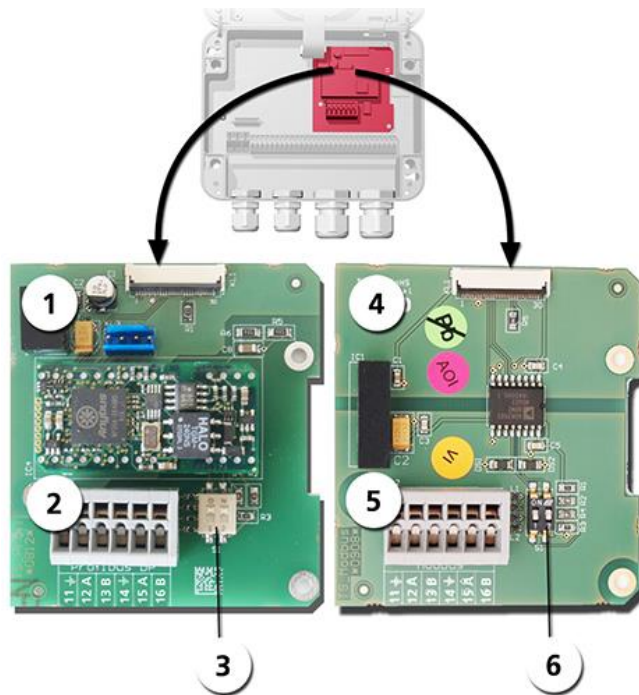

Figure 12: Overview of the Profibus DP and Modbus RTU modules

①	Field bus interface (connection printed circuit board) for Profibus DP .	④	Field bus interface (connection printed circuit board) for Modbus RTU .
②	Profibus DP terminals.	⑤	Modbus RTU terminals.
③	DIL switch for matching resistors. Switches (1 and 2) must be ON .	⑥	DIL switch for matching resistors. Switches (1 and 2) must be ON .

5.6.2 Connecting the Profibus DP or Modbus RTU

The terminals on the Profibus DP or Modbus RTU module are assigned as follows:

TERMINALS	PROFIBUS/ MODBUS	FUNCTIONAL DESCRIPTION
11 \equiv	Ground IN	Connection for cable shielding
12 A	RS 485-A IN	Data connection
13 B	RS 485-B IN	Data connection
14 \equiv	Ground OUT	Connection for cable shielding
15 A	RS 485-A OUT	Data connection
16 B	RS 485-B OUT	Data connection

5.6.3 Overview of Profinet IO

- To connect to the Profinet IO, the Profinet IO module must be integrated in the SICON (M).
- The module has an internal switch and provides two Ethernet ports.
- The cable is connected directly to the RJ45 plug of the Profinet IO module inside the instrument or via external M12 connectors.

⚠ When connecting directly to the RJ45 plug, please note that only plugs with a short and flat design can be used.

- In the **Digi.interf. \ General** menu, the **Modul type** must be set to **Profinet IO**.
- In the **Digi.interf. \ Profinet** menu, the station name, MAC address and connection status are shown. Moreover, it can be defined here whether the data should only be read or be read and written.

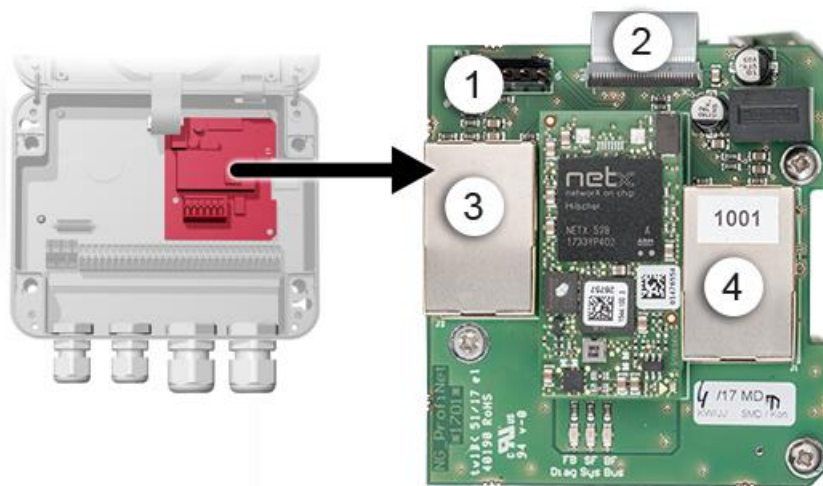

Figure 13: Overview of the Profinet IO module

①	Field bus interface (connection print) for Profinet IO	②	Connector for SICON (M)
③	Ethernet port 1 (can be used as in- or output)	④	Ethernet port 2 (can be used as in- or output)

5.6.4 Overview of HART



Information on commissioning the field bus interfaces can be found in the Reference Handbook.

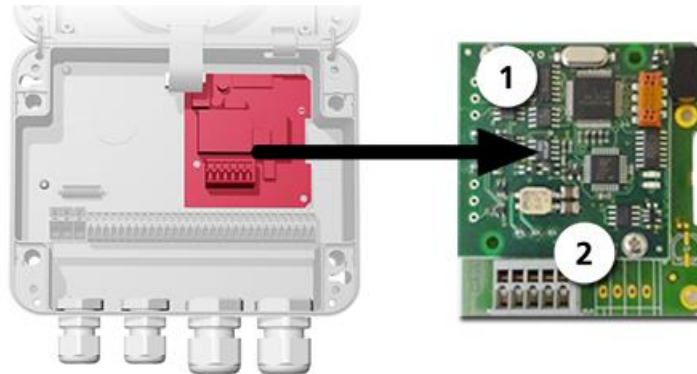

Figure14: Overview of the HART module

①	Field bus interface (connection print) for HART. Serves as interface to HART.	②	HART terminals
---	---	---	----------------

5.6.5 Connecting to HART

The terminals of the HART module are configured as follows:

Terminals	HART	Functional description
1	mA+ In	Must be connected with terminal 13 (mA 1+) of NG_Bedi.
2	mA- In	Must be connected with terminal 12 (mA 1-) of NG_Bedi.
3	Shield	Cable shielding.
4	mA+ Out	Current output 1 (+) with HART is routed to terminal 26.
5	mA- Out	Current output 1 (-) with HART is routed to terminal 25.

The loop resistance on current output 1 can be between 230 and 500 Ohm for HART communication.

HART process variables	Function	Values
Primary variable	Measuring value channel 1	Measuring value 1
Secondary variable	Measuring value channel 2	Measuring value 2
Third variable	Measuring value channel 3	Measuring value 3
Fourth variable	Reserve	
Additional status	Status	Prio / Faults / Warnings Section 10
Re-range primary variable	Upper range value	Measuring range 1 from
	Lower range value	Measuring range 1 to

5.7 Connecting the analog modules (optional)

5.7.1 Overview of 4-way current output

The configuration of the current outputs is described in the Section 8.2.

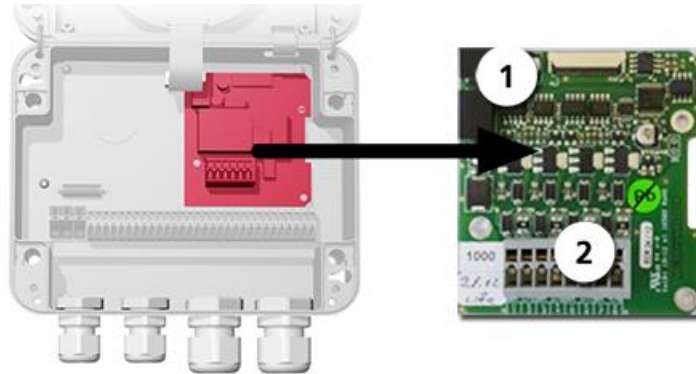

Figure 15: Overview of the 4-way current output module

①	4-way current output	②	Terminals
---	----------------------	---	-----------

5.7.2 Connecting the 4-way current output

The terminals of the 4-way current output are configured as follows:

Terminals	4-way current output	Functional description
1	mA 5 -	Current output 5
2	mA 5 +	
3	mA 6 -	Current output 6
4	mA 6 +	
5	mA 7 -	Current output 7
6	mA 7 +	
7	mA 8 -	Current output 8
8	mA 8 +	

The burden on the current outputs can be a maximum of 500 Ohm.

5.7.3 Overview of the 4-way current input

The configuration of the current inputs is described in the Reference Handbook.

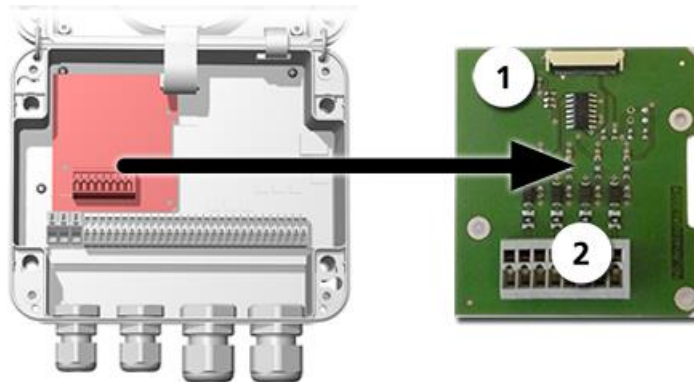

Figure 16: Overview of the 4-way current input module

①	4-way current input	②	Terminals
---	---------------------	---	-----------

5.7.4 Connecting the 4-way current input

The terminals of the 4-way current input are configured as follows:

Terminals	4-way current input	Functional description
1	In 1 -	Current input 1
2	In 1 +	
3	In 2 -	Current input 2
4	In 2 +	
5	In 3 -	Current input 3
6	In 3 +	
7	In 4 -	Current input 4
8	In 4 +	

Current inputs 1 .. 4 are intended for connecting external 0/4 .. 20 mA signals. The inputs are not galvanically isolated and the negative inputs are connected to the ground of the instrument. The input resistance is 100 Ohm.

5.8 Connecting the optional 24 VDC power supply



DANGER!

Life-threatening voltage due to accidentally released voltage-carrying wires.

- The wires of the supply connection must be secured with cable ties so that if one wire accidentally becomes loose no other parts can be charged with voltage.
- Cable with an outer diameter of 4 to 8 mm must be used.

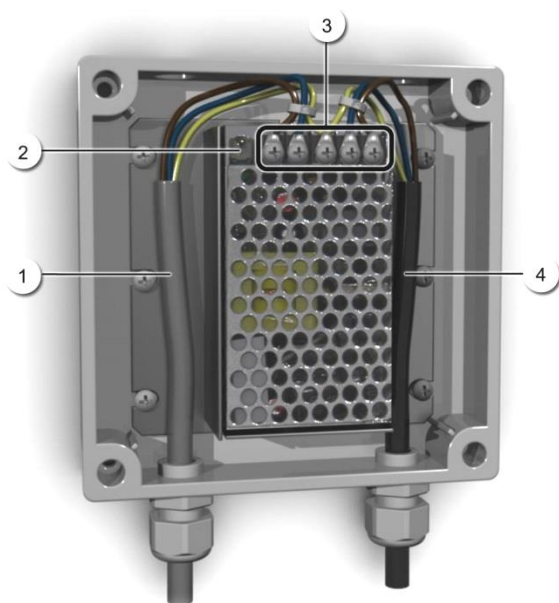

Figure 17: Optional power supply with removed cover

①	Cable to SICON (24 VDC)	②	Indicator lamp
③	Screw terminals	④	Cable from mains (100-240 VAC)

The terminals are assigned as follows for connecting the mains device:

Terminal designation in the power supply	Cable color	Terminal designation in the SICON	Function
+24 V	Brown	2: 9 V to 30 V	24 VDC
RTN	Blue	3: GND	Ground
Protective ground	Yellow-green	1: Ground connection	Ground connection
Protective ground			Mains protective ground
N			Mains neutral conductor
L			Mains live





6 Commissioning



- The initial start-up of the web user interface via the Ethernet interface is described in the Reference Handbook.
- Consult the corresponding documentation when using a SICON M (document no. 11775 / 11776).
- If malfunctions occur, consult the Section 10.

Proceed with the initial start-up in accordance with the following table:



	WORKSTEP	ADDITIONAL INFO / IMAGES
1.	Ensure that the photometer and control unit are correctly mounted and connected.	Section 4 and Section 5
2.	2.1: Establish the service voltage to the photometer and switch it on. The welcome screen appears on the display.  The factory setting language is English. Accordingly, the displayed language during the initial start-up is English.	
	2.2: The instrument carries out an internal functional check.	
	2.3: The instrument is ready for measurement.	
3.	Set the language.	Section 8.1
4.	Set the current outputs.	Section 8.2
5.	Set the limits.	Section 8.3
6.	Set the outputs.	Section 8.4
7.	Set the optional functions according to the Reference Handbook.	For example, cleaning cycle with ColorPlus 2, analog input compensation

	WORKSTEP	ADDITIONAL INFO / IMAGES
8.	Set the date and time.	Section 8.5
9.	Enter the access code.	Section 8.6
10.	Carry out recalibration.	Section 9.9
11.	Back up the configured data.	Section 8.7

7 Operation

7.1 Operation basics

In this document we describe the practical examples only for the first steps of the menu configuration. All other setting options are described in the Reference Handbook. Operation using the web user interface is described in detail in the Reference Handbook.



The instrument has a touchscreen. It is operated by touching with your finger. The navigation elements change color when touched.



CAUTION!

Sensitive touchscreen.

The touch screen can be damaged through improper handling. Damage can be avoided with the following measures:

- Touch the touchscreen only with your fingers and not with sharp objects.
- Use only slight pressure to perform manipulations on the touchscreen.
- Do not use chemicals or solvents to clean the touchscreen.

7.2 Control elements in measuring mode



Figure 18: Control elements in measuring mode

①	Menu button Calls up the menu structure. Section 7.3	②	Valu button Numerical representation of the measuring values. Section 7.4
③	Info button Displays the information screen. Section 7.5	④	Diag button Graphical representation of the measuring values. Section 7.6
⑤	Up arrow Goes to the previous page.	⑥	Down arrow Goes to the next page.

7.3 Menu button

Pressing the **Menu** button and entering the access code takes you to the menu structure. Now the instrument is in service mode. Operator prompting in service mode is described in Section 7.11.

7.4 Valu button

Pressing the **Valu** button displays the measuring values in numerical form. This is described in detail in Section 7.8.

7.5 Info button

When you press the Info button, a general overview of the instrument settings appears. These are described below:

7.5.1 Page 1, Info button

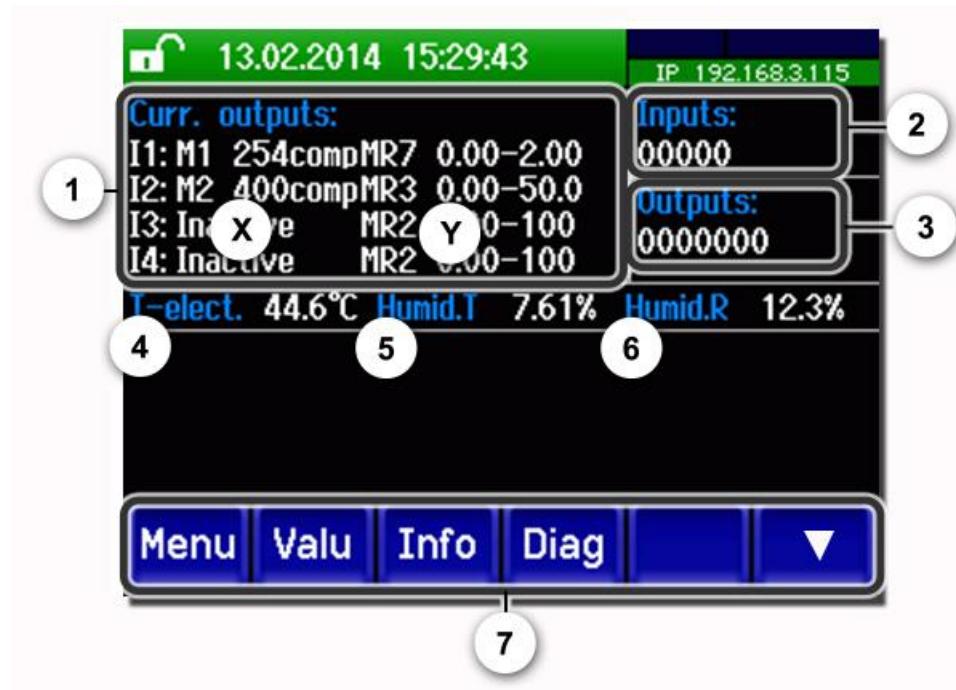

Figure 19: Info screen, page 1

<p>① Information about the available current outputs X: Source of the current output Y: Measuring range of the current output</p>	<p>② Status of the inputs → Reference Handbook</p>
<p>③ Status of the outputs → Reference Handbook</p>	<p>④ Temperature of the electronics</p>
<p>⑤ Humidity in transmitter housing</p>	<p>⑥ Humidity in receiver housing</p>
<p>⑦ Main menu buttons</p>	

7.5.2 Page 2, Info button

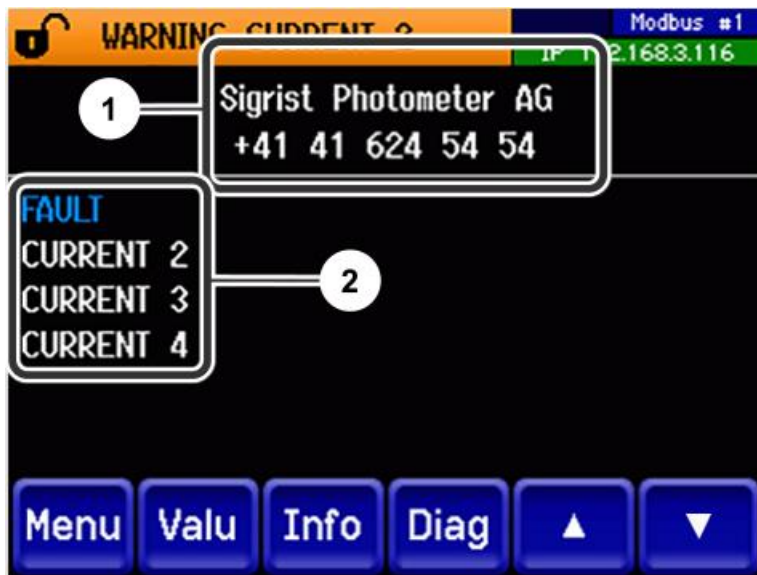

Figure 20: Info screen, page 2

①	Contact information	②	Display of up to 5 pending fault messages
---	---------------------	---	---

7.6 Diag button

When you press the **Diag** button, a diagram appears which graphically shows the measuring values over a certain period of time.

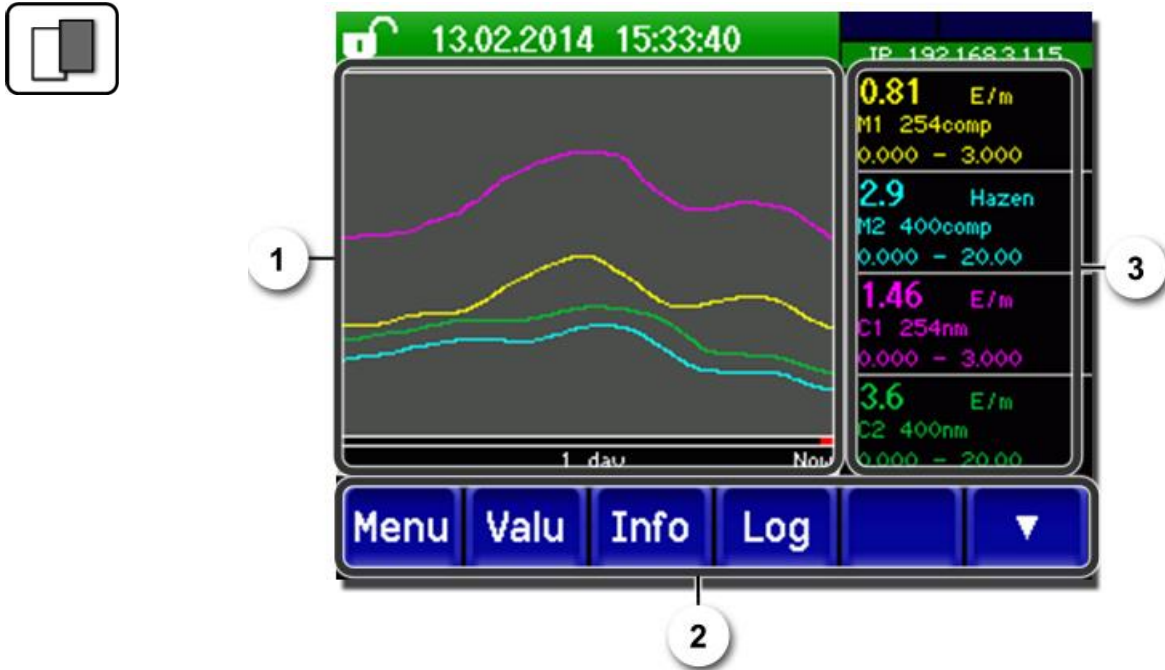

Figure 21: Graphic representation of the measuring values

<p>① Graphic representation of the measuring values The measuring values can be recorded from 3 minutes to 32 days and are graphically represented. The color of the measuring value curves corresponds to the measuring channels on the right side of the display (position 3).</p>	<p>② Main menu buttons 1 The logger functions (Log button) are described in Section 7.7.</p>
<p>③ Measuring channels: Numerical representation of the set measuring channels.</p> <ul style="list-style-type: none"> ▪ Current measuring value ▪ Measuring channel with name ▪ Scaling of the Y-ax 	

7.7 Functions of the log screen (Log button)



The screen logger works independently of the data logger, which is set in the **Logger** menu and writes to the microSD card.

The screen logger records the data of the last 32 days in one-minute intervals. The data can be called up from the Log menu.

If the instrument is out of operation for more than 32 days, the logger data is reinitialised. An hourglass is shown for about 1.5 minutes in the graphic display. During this time, no logger data is available.

The **Log** button is found only in the main menu in the graphic screen; in the **Valu** screen, the **Diag** button has to be pressed first. When the **Log** button is pressed, the following screen appears:



Figure 22: Functions of the Log display

<p>① The cursor shows the time position which is represented at pos. 4. The cursor position can be changed either by briefly touching with your fingertip or by pressing the </> buttons.</p>	<p>② Represented time period The following time ranges can be set: 3 min./15 min./1 hour/ 3 hours/9 hours/1 day/3 days/10 days/ 32 days</p>
<p>③ The red bar indicates how much of the total time period is currently represented.</p>	<p>④ Measuring value which was measured at the cursor position.</p>
<p>⑤ </>: Moves the cursor position. The cursor moves faster when these buttons are held down longer. <</>>: Jumps forward or backward by the time period set in point 2. -/+ : Increases (+) or decreases (-) the screen section around the cursor position.</p>	



In the **Display/General** menu, you can define whether minimum, maximum or mean values are to be displayed. → Reference Handbook
Pressing the **Diag** button takes you to the graphical representation.

7.8 Displays in measuring mode











Figure 23: Displays in measuring mode

<p>①</p>	<p>Measuring value(s) For values which are greater than the maximum measuring range, no measuring value is displayed; instead **** is displayed.</p>	<p>②</p>	<p>Status line In measuring mode, the status line is green and shows the date and time. i If faults should occur, warning and fault messages are shown here and the status line changes to orange or red.</p>								
<p>③</p>	<p>Interface information</p> <ul style="list-style-type: none"> ▪ Top left: Logger status ▪ Top right: Modbus, HART, Profinet or Profibus status ▪ Below: Ethernet IP status The following messages are possible: <ul style="list-style-type: none"> - IP not connected (cable not connected) - IP DHCP running... - IP 169.254.1.1 (example address) <p>Color coding:</p> <table border="1" data-bbox="480 1641 879 1865"> <tr> <td>Black</td> <td>Not active / not present</td> </tr> <tr> <td>Blue</td> <td>Activated, in quiescent mode</td> </tr> <tr> <td>Green</td> <td>Active</td> </tr> <tr> <td>Red</td> <td>Fault</td> </tr> </table>	Black	Not active / not present	Blue	Activated, in quiescent mode	Green	Active	Red	Fault	<p>④</p>	<p>Channel name with unit i The channel names shown in the figure are examples and can be adjusted individually.</p>
Black	Not active / not present										
Blue	Activated, in quiescent mode										
Green	Active										
Red	Fault										

7.9 Lock / unlock the touch screen



MANIPULATION						
1.	Press the lock icon top left.					
2.	<p>Within one second press the key bottom at the outside right.</p> <p>Depending on the initial state, the lock icon changes as follows:</p> <table border="1" data-bbox="451 835 991 981"> <tbody> <tr> <td></td> <td>Touch screen unlocked</td> </tr> <tr> <td></td> <td>Touch screen locked</td> </tr> </tbody> </table>		Touch screen unlocked		Touch screen locked	
	Touch screen unlocked					
	Touch screen locked					

7.10 Switching to service mode

The system is configured in service mode. The measuring procedure is interrupted and the main menus appear on the display. Service mode is accessed as follows:



	MANIPULATION	ADDITIONAL INFO / IMAGES
1.	Press the Menu button.	
2.	Enter the access code and confirm with OK .	 Factory setting is 0 .
3.	The main menus appear.	The instrument is now in service mode.

The following applies in service mode:

- * The measuring values remain on the last values on the digital interfaces.
- * Depending on the configuration, the current outputs go to 0/4 mA or remain on the last measuring values.
- The limits are deactivated.
- If an output for service is programmed, it is activated.
- Fault messages are suppressed.

* This does not apply when the **Current outputs\General\For service** parameter is set to **Measure**.



For measuring mode, press the **Meas** button. When switching from service mode to measuring mode, an hourglass appears in the information bar for about 10 seconds. The measuring values are frozen during this time.

7.11 Control components in service mode

7.11.1 Input elements in service mode

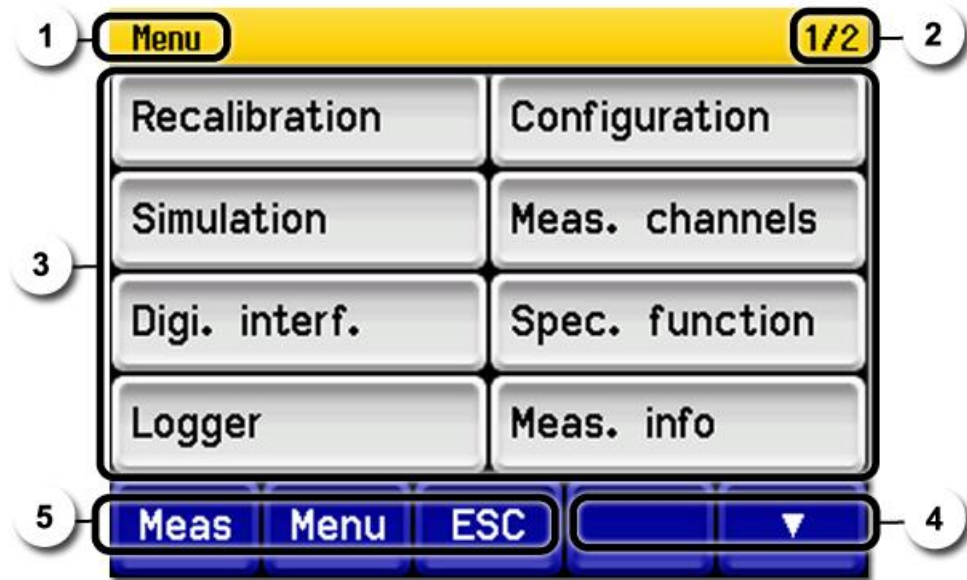
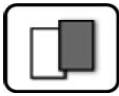

Figure 24: Input elements in service mode

①	Path specification	②	Page number / total number of pages
③	Main menus Instrument-specific menus of the photometer.	④	Next page
⑤	Meas button: The instrument changes to measuring mode. Menu button: The display goes back to main menus and remains in service mode. ESC button: The display goes back one level in the menu hierarchy until the measuring mode finally is reached.		

7.11.2 Numerical entry

The following screen is for entering numbers and data:

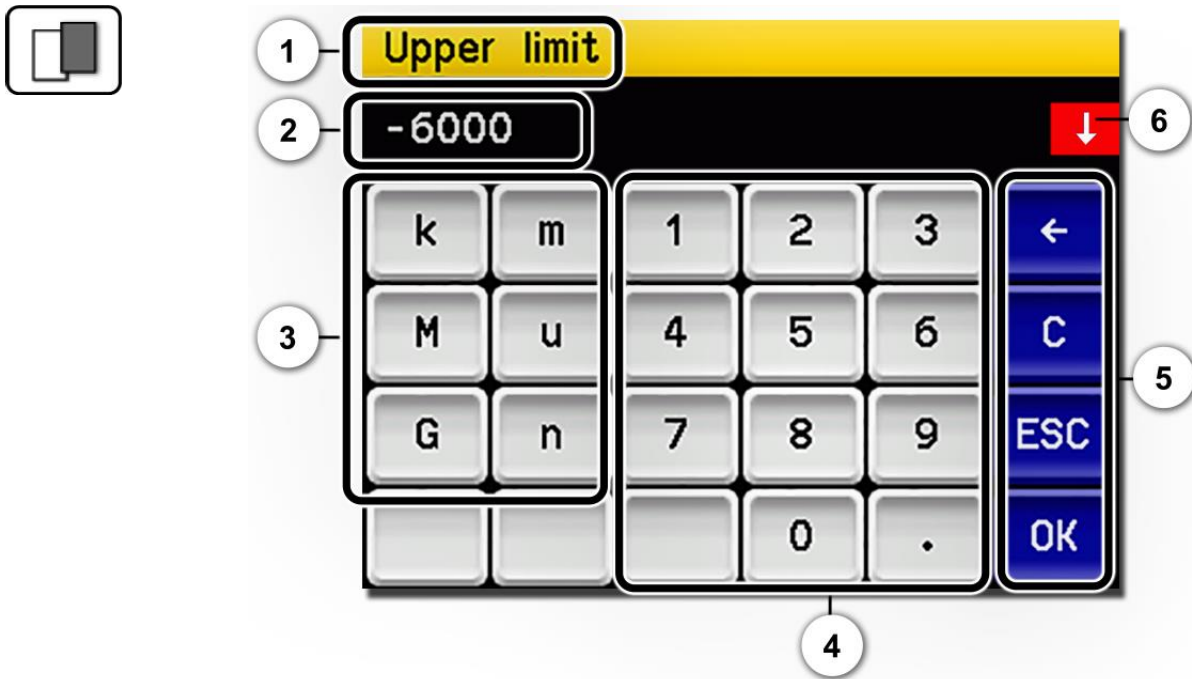
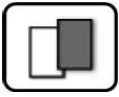

Figure 25: Numerical entry

①	Parameter name	②	Entered values
③	Prefix: For entering very large or very small values. This can be done as follows: 1. Enter value 2. Select SI prefix Function: $n = 10^{-9}$, $u = 10^{-6}$, $m = 10^{-3}$, $k = 10^3$, $M = 10^6$, $G = 10^9$	④	Numerical entry
⑤	\leftarrow : Deletes one digit of the displayed value. C : Clears the displayed value. ESC : Touching the ESC field causes the display to go back one level in the menu hierarchy. The entered value is not saved. OK : Confirm entered value.	⑥	If the value entry is too high or too low, a white arrow appears in a red field top right. Arrow points upward: Entry too high Arrow points downward: Entry too low

7.11.3 Single selection of functions



The single selection is identifiable by the **ESC** button in the lower right corner.

The currently selected function is green. Use the Up/Down arrows to navigate the options in long lists. Use the **ESC** button to cancel the entry. Pressing a selection item saves the configuration and completes the entry.



Figure 26: Example of single selection

7.11.4 Multiple selection of functions

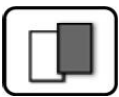

The multiple selection is identifiable by the **OK** button in the lower right corner.

The currently selected values are green. Use the Up/Down arrows to navigate the options in long lists. Pressing a selection item changes the active status of the corresponding item. Press the **OK** button to save the configuration and complete the entry.



Figure 27: Example of multiple selection

8 Settings

8.1 Setting the operating language



	MANIPULATION	ADDITIONAL INFO / IMAGES
1.	Press the Menu button.	
2.	Enter the access code and confirm with OK .	i Factory setting is 0 .
3.	Press the Configuration button to access language selection.	i If the desired menu does not appear, press the arrow bottom right.
4.	Press language field (circle). The list of all languages appears (factory setting is English).	
5.	Apply the desired language by pressing the corresponding field, or press the ESC button to cancel.	
6.	Press the Meas button.	The instrument is in measuring mode again.

8.2 Setting the current outputs



	MANIPULATION	ADDITIONAL INFO / IMAGES
1.	Press the Menu button.	
2.	Enter the access code and confirm with OK .	i Factory setting is 0 .
3.	Press the Curr. outputs button.	i If the desired menu does not appear, press the arrow at the bottom right.
4.	Select between C1 .. 4 .	
5.	Select the source.	The following selection is available: <ul style="list-style-type: none"> ▪ C1 .. n (measuring channels) ▪ M1 .. 3 (math channels) ▪ A1 .. 2 (analog channels) ▪ Humidity
6.	Select the Range .	MR1 .. MR8 In 1, In 2, Auto 1, Auto 2 → Reference Handbook
7.	Press the Meas button.	The instrument is in measuring mode again.

Eight measuring ranges are pre-programmed in the instrument according to the parameter list. If other measuring ranges are required, these can be reprogrammed according to the parameter list or your own requirements. → Reference Handbook

8.3 Setting the limits

The limits have to be configured accordingly so that they are not only displayed, but that the outputs are also switched. Section 8.4



	MANIPULATION	ADDITIONAL INFO / IMAGES
1.	Press the Menu button.	
2.	Enter the access code and confirm with OK .	i Factory setting is 0 .
3.	Press the Limits button.	i If the desired menu does not appear, press the arrow at the bottom right.
4.	Select between L1 .. n .	
5.	Select the source.	The following selection is available: <ul style="list-style-type: none"> ▪ C1 .. n (measuring channels) ▪ M1 .. 3 (math channels) ▪ A1 .. 2 (analog channels) ▪ Humidity
6.	Define the Mode .	The following selection is available: <ul style="list-style-type: none"> ▪ Inactive (limit monitoring of this channel is deactivated) ▪ Exceeded (limit active when the set threshold value is exceeded) ▪ Undershot. (limit active when the set threshold value is undershot)
7.	Define the upper limit, lower limit, cut-in delay and cut-out delay with the number pad.	i Pressing the current number value takes you to the entry mode.
8.	Press the Meas button.	The instrument is in measuring mode again.

8.3.1 Upper and lower threshold value of a limit

A maximum of eight limits with upper and lower threshold can be programmed.

If the operating mode is set to **Exceeded** (Figure 28), then while the upper threshold is exceeded the limit is active and remains active until the lower threshold is again under-shot.

If the operating mode is set to **Undershot**, then while the lower threshold is undershot the limit is active and remains active until the upper threshold is again exceeded.

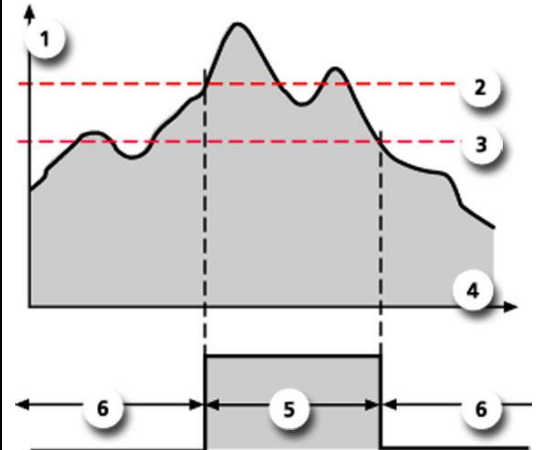
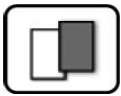

Figure 28: Threshold diagram

①	Measuring value	②	Upper threshold
③	Lower threshold	④	Time
⑤	Limit active	⑥	Limit passive

8.3.2 Reading if limit exceeded or undershot



If a limit event occurs during operation, it has the following effects on measuring mode:

- Threshold value display indicates an unusual state.
- If an output for the corresponding limit channel is programmed, it is switched.

If the message **Limit** appears, the color of the status display changes to **white** and the numbers of the limit channels are listed with their channel numbers in **red** if limits have been exceeded or undershot. Inactive limits are indicated with "_".







8.4 Setting the outputs



	MANIPULATION	ADDITIONAL INFO / IMAGES
1.	Press the Menu button.	
2.	Enter the access code and confirm with OK .	i Factory setting is 0 .
3.	Press the Inp./outputs button.	i If the desired menu does not appear, press the arrow at the bottom right.
4.	Press the Outputs button.	
5.	Select O1 Inactive .. O7 Inactive Output .	
6.	Activate the outputs (multiple selection possible).	<p>Activated outputs are highlighted green.</p> <ul style="list-style-type: none"> ▪ Invert: Inverts the outputs ▪ Prio fault ▪ Fault ▪ Warning ▪ Service ▪ Adjustment ▪ Sensor check ▪ Humidity ▪ Limit 1 .. 4 <p>The other buttons named MR-Out... are for automatic measuring range switching → Reference Handbook.</p>
7.	Press the Meas button.	The instrument is in measuring mode again.

8.5 Setting the date and time





	MANIPULATION	ADDITIONAL INFO / IMAGES
1.	Press the Menu button.	
2.	Enter the access code and confirm with OK .	 Factory setting is 0 .
3.	Press the Configuration button.	 If the desired menu does not appear, press the arrow bottom right.
4.	To enter the time, press the currently displayed time at the Time menu item and enter the new time with the number pad. Confirm entry with OK .	The time must be entered in the format hh:mm:ss . 
5.	To enter the date, press the currently displayed date at the Date menu item and enter the new date with the number pad. Confirm entry with OK .	The date must be entered in the format selected under the Date format menu item. 
6.	Press the Meas button.	The instrument is in measuring mode again.

8.6 Setting or changing the access code

You can protect the settings of the instrument against unauthorized manipulations by defining your own access code.



	MANIPULATION	ADDITIONAL INFO / IMAGES
1.	Press the Menu button.	
2.	Enter the access code and confirm with OK .	 Factory setting is 0 .
3.	Press the Configuration button.	 If the desired menu does not appear, press the arrow bottom right.
4.	Press the button to the right of the Access code description text.	
5.	Enter the access code and confirm with OK .	
6.	Press the Meas button.	The instrument is in measuring mode again.



A forgotten access code can be cleared only by a SIGRIST service engineer.

Enter your personal access code here:

--	--	--	--	--	--

8.7 Backup configured data

These measures can be of use to the service engineers for service purposes.



	MANIPULATION	ADDITIONAL INFO / IMAGES
1.	Press the Menu button.	
2.	Enter the access code and confirm with OK .	i Factory setting is 0 .
3.	Press the System info. button.	i If the desired menu does not appear, press the arrow bottom right.
4.	In the User -> SD and Expert -> SD submenus press the Copy function.	The user and expert data are copied to the microSD card. After a successfully completed procedure, acknowledge with the OK button.
5.	Press the Meas button.	The instrument is in measuring mode again.

9 Servicing



CAUTION!

Damage to the instrument due to servicing duties that have not been carried out or have been carried out improperly.

If servicing duties are not carried out according to the servicing schedule or non-original SIGRIST spare parts are used, this can lead to damage to the instrument or measuring errors. In this case, SIGRIST-PHOTOMETER AG accepts no warranty claims made by the customer and is not responsible for any subsequent costs. To avoid this situation, please adhere to the following steps:

- Carry out servicing duties according to the servicing schedule (Section 9.1).
- When carrying out servicing duties, use original SIGRIST spare parts according to the spare parts list (Section 15). The use of third-party spare parts requires the written approval of SIGRIST-PHOTOMETER AG.
- If the instruments are subjected to heavy use or exposed to severe environmental conditions, servicing duties must be carried out more often as required. Wear parts in particular must be replaced more often depending on the circumstances.

9.1 Servicing schedule

WHEN	WHO	WHAT	PURPOSE
As needed	Operator	Refill with cleaning agent for the 4 th clarification stage  Handling depends on the agent used and must be adapted accordingly.	Obligatory measure for maintaining measuring accuracy. Interval dependent on measuring medium.
		Carry out normal cleaning of the bypass measuring cell (100/50 mm optical path length) (Section 9.2)	
		Clean/replace the measuring cell window (Section 9.3/ Section 9.4/ Section 9.5/ Section 9.6)	
Annually or as needed	Operator	Cleaning the outside of the instrument	Dirt on the outside of the photometer does not have any effect on the measuring results. Cleaning is thus not absolutely essential.
Annually or in the event of a warning	Operator	Replace the desiccant on the transmitter/receiver (Section 9.7/ Section 9.8)	Obligatory measure for maintaining measuring accuracy.
Every 3 months or more often (as needed)	Operator	Recalibrate the photometer (Section 9.9/ Section 9.10)	Measure for maintaining measuring accuracy. Interval dependent on measurement surroundings.
Annually or as needed	Operator	Functional check with external checking unit (Section 9.11)	Obligatory measure for maintaining measuring accuracy.
Every 2 years	Operator	Replace the UV light source (Section 9.12)	Measure for maintaining measuring functionality.
Every 10 years or as needed	Operator	Change the battery in the SICON (Section 9.13)	Obligatory measure for maintaining functional efficiency.

Table 1: Servicing schedule

9.2 Cleaning of the bypass measuring cell

The following procedure describes how to clean the bypass measuring cell (100/50 mm optical path length):

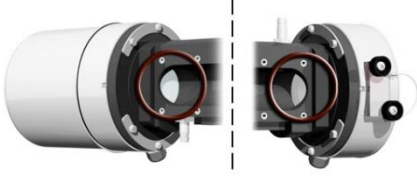

	WORKSTEP	ADDITIONAL INFO / IMAGES
1.	Stop the sample flow and let the measuring cell run dry.	
2.	2a. Process for 100 mm optical path length: 1. Loosen the knurled screws (1 - 6) and remove the cover with compensation glass. <div style="border: 1px solid black; padding: 5px; margin-top: 10px;"> The compensation glass is found on the inside of the cover. Remove the cover carefully. </div>	
	2. Replace the seal (X) if this is no longer in perfect condition. 3. Clean the compensation glass (circle) with a suitable cleaning agent. Replace the compensation glass if it is scratched or tarnished. <div style="border: 1px solid black; padding: 5px; margin-top: 10px;"> The compensation glass is found only on bypass measuring cells. This servicing duty is not required on inline measuring cells. </div>	
	2b. Process for 50 mm optical path length: 1. Loosen both knurled screws (circles) and carefully remove the fixing bar. The compensation glass is mounted on the rear of the fixing bar and forms a unit together with it. <div style="border: 1px solid black; padding: 5px; margin-top: 10px;"> Do not damage the glass on the fixing bar. </div>	
	2. Replace the seal (B) if this is no longer in perfect condition.	
	3. Clean the compensation glass (A) with a suitable cleaning agent. Replace the compensation glass if it is scratched or tarnished.	

	WORKSTEP	ADDITIONAL INFO / IMAGES
3.	Clean the measuring cell windows inside the measuring cell (circles). In the event of heavy soiling on the measuring cell windows, consult Section 9.3.	
4.	Reassemble the instrument in reverse order.	
5.	Carry out recalibration according to Section 9.9.	



9.3 Replacing the measuring cell windows

The following procedure can be used for the following bypass measuring cells (100/50 mm optional path length):

- PVC measuring cell (water)
- VA measuring cell (ozone)
- PVDF measuring cell (chlorine)

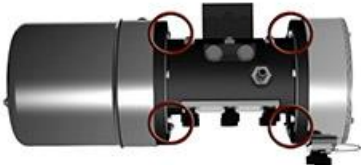

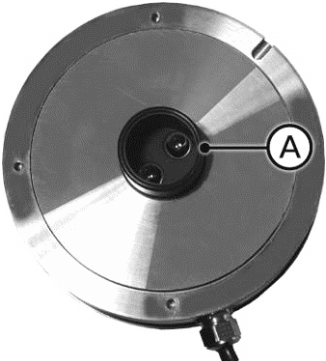

	WORKSTEP	ADDITIONAL INFO / IMAGES
1.	Stop the sample flow and let the measuring cell run dry.	
2.	Interrupt the service voltage to the photometer.	
3.	Carry out normal cleaning of the bypass measuring cell (100/50 mm optical path length) according to Section 9.2.	
4.	Remove the transmitter and receiver from the measuring cell by loosening each set of four hex bolts (circles). <div style="border: 1px solid black; padding: 5px; background-color: #f0f0f0;"> <p>⚠ Do not put the connection cable of the transmitter/receiver under stress (ensure the transmitter is placed on a firm surface after disassembly). Keep a firm hold of the transmitter/receiver during disassembly.</p> </div>	





	WORKSTEP	ADDITIONAL INFO / IMAGES
5.	<p>Clean the measuring cell windows on the transmitter/receiver side.</p> <p>If cleaning of the measuring cell windows was successful, then continue from point 11.</p> <p>If cleaning of the measuring cell windows was not successful, then continue from point 6.</p>	
6.	<p>Remove the screw connection on the measuring cell with the special wrench (32 mm).</p>	
7.	<p>The screw connection, pressure ring, seal and measuring cell windows can now be removed.</p>	
8.	<p>Clean the measuring cell windows with a suitable cleaning agent.</p> <p>Ensure that the measuring cell windows are no longer soiled during the subsequent assembly.</p> <p>Replace the measuring cell window and seal, if required.</p>	
9.	<p>Replace the seal on the flood protection (A), if required.</p>	
10.	<p>Reassemble the instrument in reverse order.</p>	
11.	<p>Carry out recalibration according to Section 9.9.</p>	

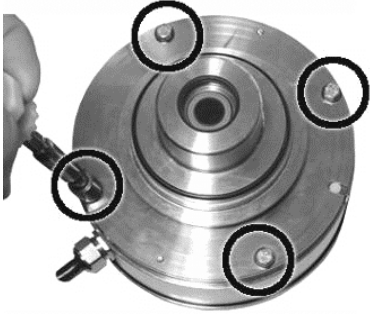
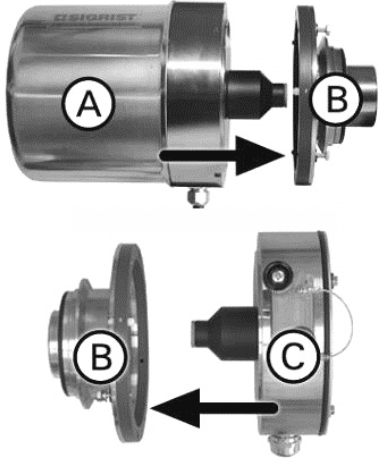

9.4 Replacing or cleaning the measuring cell windows on the VARINLINE® housing

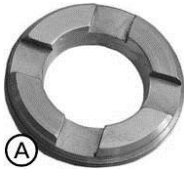
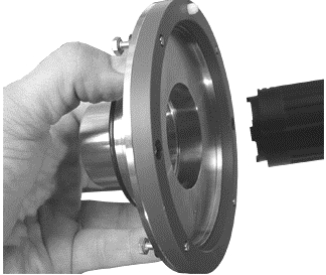
The following procedure describes how to clean the windows on the VARINLINE® housing:

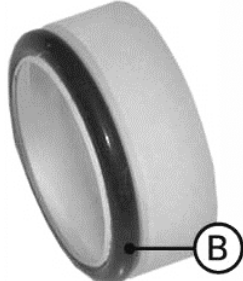
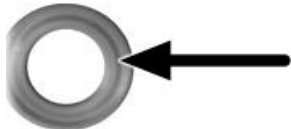
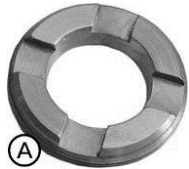
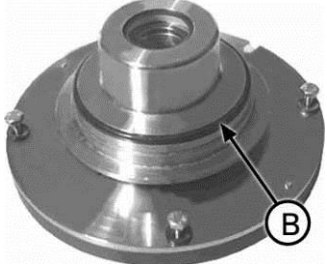

	WORKSTEP	ADDITIONAL INFO / IMAGES
1.	Stop the sample flow and let the measuring cell run dry.	
2.	Interrupt the service voltage.	
3.	Loosen the nuts (A) and remove the lock rings on the transmitter and receiver side.	
4.	Remove the transmitter (A) and receiver (B) including OPL bit from the inline measuring cell (C) and place them on a firm surface. <div style="border: 1px solid black; padding: 5px;"> <p> Do not put the connection cable of the transmitter/receiver under stress (ensure the transmitter is placed on a firm surface after disassembly). Keep a firm hold of the transmitter/receiver during disassembly.</p> </div>	
5.	Remove the four hex bolts (circles) on the ring adapter of the transmitter and receiver.	
6.	Pull off the ring adapter (B) (including attached OPL bit) from the transmitter (A) and receiver (C).	

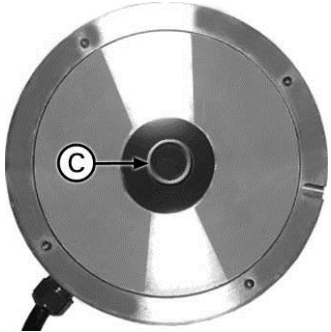
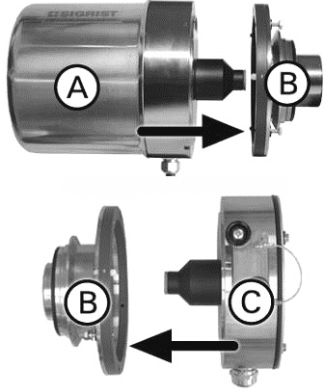
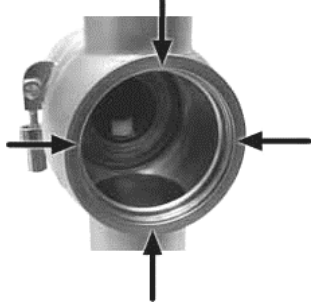
	WORKSTEP	ADDITIONAL INFO / IMAGES
7.	Remove the ring nut (A) in the OPL bit with an OPL bit wrench. 	
8.	Remove the pressure ring (A) and measuring cell window with seal (B) from the OPL bit. Remove the seal from the measuring cell window and clean with a paper towel or cloth and warm, soapy water, if required. <hr/>  Replace the measuring cell windows, if required.	
9.	Position the seal (B) in the groove of the measuring window. Replace the seal, if required. <hr/>  The measuring cell window is inserted in the OPL bit with the seal facing downwards.	
10.	Insert the pressure ring in the OPL bit with the groove (arrow) facing downwards.	
11.	Screw in the ring nut (A) and fasten in place using the OPL bit wrench.	
12.	If required, position a new seal (B) in the groove of the OPL bit.	

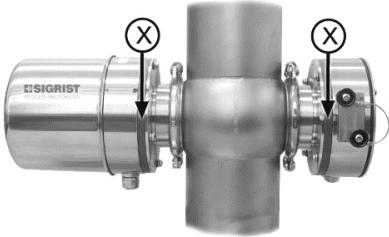
	WORKSTEP	ADDITIONAL INFO / IMAGES
13.	Position the seal (C) in the groove of the flood protection. <hr/>  If required, replace the seal (C) of the flood protection.	
14.	Attach the ring adapter (B) (including attached OPL bit) on the transmitter (A) and receiver (C) and fasten in place with the four hex bolts.	
15.	Clean all contact surfaces (arrows) on the inline housing.	
16.	Reinsert the transmitter and receiver with attached ring adapter and OPL bit into the inline housing. <hr/>  The groove (X) on the transmitter and receiver must face forwards when mounted.	
17.	Fasten the transmitter and receiver back onto the inline housing using the lock rings.	
18.	Carry out recalibration according to Section 9.9.	

9.5 Cleaning or replacing the measuring cell windows on the sliding measuring cell

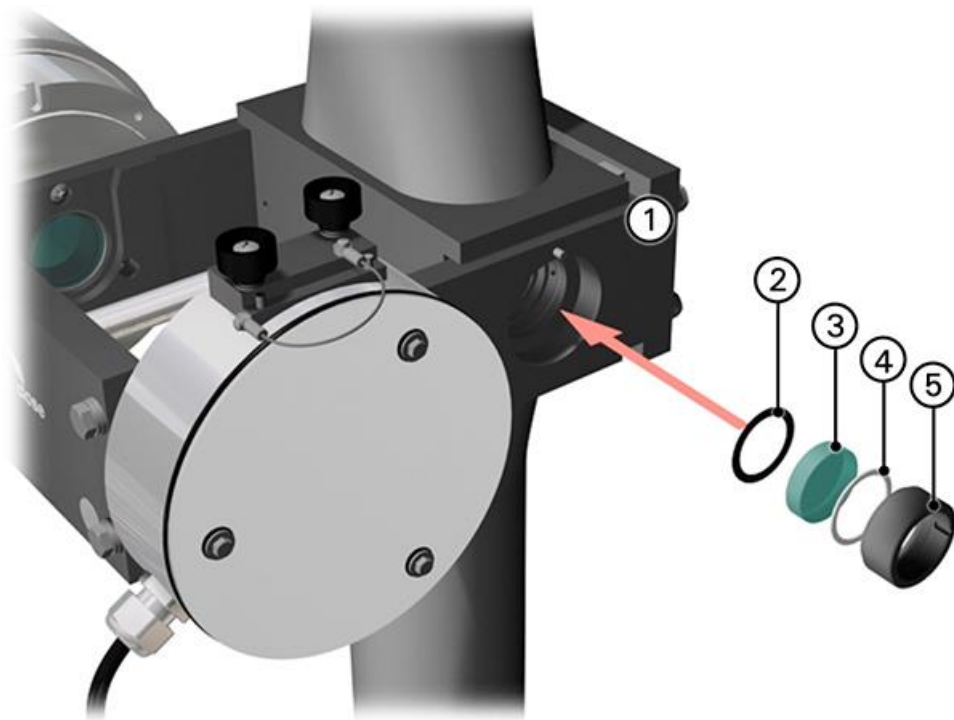



Figure 29: Cleaning the measuring cell windows, sliding measuring cell

①	Sliding measuring cell	②	Kalrez seal, or other
③	Measuring cell window	④	Teflon slide ring
⑤	Ring nut		

The cleaning or replacement process is the same for both measuring cell windows. The following steps describe the procedure for only one window.



	WORKSTEP	ADDITIONAL INFO / IMAGES
1.	Stop the sample flow and let the measuring cell run dry.	
2.	Loosen the lock (X).	

	WORKSTEP	ADDITIONAL INFO / IMAGES
3.	Slide the photometer from the measurement position.	
4.	Remove the ring nut (Figure 29, pos. 5) using the face wrench.	
5.	Remove the Teflon slide ring (Figure 29, pos. 4), measuring cell window (Figure 29, pos. 3) and the seal (Figure 29, pos. 2) from the bore.	
6.	<p>Clean the measuring cell window with a paper towel, cloth or warm, soapy water.</p> <hr/> <p>i Replace the seal or measuring cell window, if required.</p>	
7.	Position the seal (Figure 29, pos. 2) in the bore.	
8.	Reposition the measuring cell window (Figure 29, pos. 3) in the bore.	
9.	Position the Teflon slide ring (Figure 29, pos. 4) on the measuring cell window.	
10.	<p>Screw in the ring nut (Figure 29, pos. 5) with the special wrench.</p> <hr/> <p>! Do not fasten too tightly, as the measuring cell windows can break.</p>	
11.	Slide the instrument back into the measurement position and fasten in place with the locking screw.	
12.	Carry out recalibration according to Section 9.9.	

9.6 Cleaning or replacing the windows on the calibration measuring cell

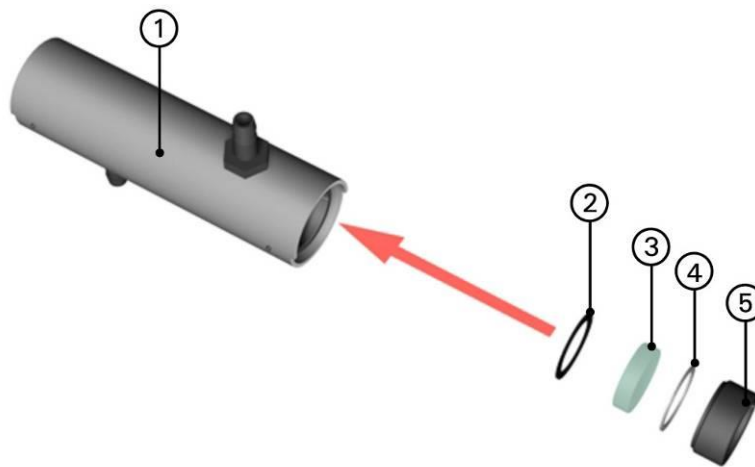



Figure 30: Calibration measuring cell window

①	Calibration measuring cell	②	Neoprene seal
③	Measuring cell window	④	Teflon slide ring
⑤	Ring nut		

The cleaning or replacement process is the same for both calibration measuring cell windows. The following steps describe the procedure for only one window.



	WORKSTEP	ADDITIONAL INFO / IMAGES
1.	Remove the ring nut (Figure 30, pos. 5) using the face wrench.	
2.	Remove the Teflon slide ring (Figure 30, pos. 4), measuring cell window (Figure 30, pos. 3) and the seal (Figure 30, pos. 2) from the calibration measuring cell.	

	WORKSTEP	ADDITIONAL INFO / IMAGES
3.	<p>Clean the measuring cell window with a paper towel, cloth or warm, soapy water.</p> <hr/> <p> Replace the seal or measuring cell window, if required.</p> <hr/>	
4.	<p>Position the seal (Figure 30, pos. 2) in the bore of the calibration measuring cell.</p>	
5.	<p>Reposition the measuring cell window (Figure 30, pos. 3) on the seal.</p>	
6.	<p>Position the Teflon slide ring (Figure 30, pos. 4) on the measuring cell window.</p>	
7.	<p>Screw in the ring nut (Figure 30, pos. 5) with the special wrench.</p> <div style="background-color: #e0e0e0; padding: 5px;"> <p> Do not fasten too tightly, as the measuring cell windows can break.</p> </div>	

9.7 Replacing the desiccant on the transmitter



DANGER!

Danger of injuries on the UV light source caused by electric shocks, UV radiation and high temperatures.

When replacing the desiccant, careless handling can lead to electric shocks, eye injuries caused by UV radiation and burns due to temperatures in excess of 80 °C. It is thus essential to observe the following safety measures when removing the UV light source:

- The service voltage must be interrupted before opening the housing.
- The instrument must not be operated when the housing is removed under any circumstances.
- Before opening, wait until the instrument has cooled down to a manageable temperature.

The following procedure describes how to replace the desiccant on the transmitter:



	WORKSTEP	ADDITIONAL INFO / IMAGES
1.	Interrupt the service voltage to the photo-meter.	
2.	Loosen the three hex bolts and remove the housing.	
3.	Replace the desiccant as follows: Remove the old, saturated desiccant bag (A). On the new desiccant bag, shake and roll up the contents at one end. The new desiccant can then be used.	
4.	Check the housing seal (B) and replace, if required. Check also the cover screw seals and replace, if required.	
5.	Reassemble the instrument in reverse order.	

9.8 Replacing the desiccant on the receiver

The following procedure describes how to replace the desiccant on the receiver:



	WORKSTEP	ADDITIONAL INFO / IMAGES
1.	Interrupt the service voltage to the photometer.	
2.	Loosen the three hex bolts and remove the cover on the receiver.	
3.	Replace the desiccant as follows: Remove the old, saturated desiccant bag (A). On the new desiccant bag, shake and roll up the contents at one end. The new desiccant can then be used.	
4.	Check the housing seal (B) and replace, if required. Check also the cover screw seals and replace, if required.	
5.	Reassemble the instrument in reverse order.	

9.9 Recalibrating the photometer



Recalibrating the photometer can result in deviations from the previous measuring value as the instrument is newly reset to a reference value (e.g. distilled water).



	WORKSTEP	ADDITIONAL INFO / IMAGES
1.	<p>Fill the measuring cell with a zero medium (e.g. DI Water).</p> <p>Pay attention to the attached document on confirming calibration here.</p>	There must be no air bubbles in the measuring cell during recalibration (low flow, light counter pressure).
2.	2.1: Press the Menu button.	
	2.2: Set the access code and confirm with OK .	Factory setting is 0 .
	<p>2.3: Select the Recalibration menu and then press C1. Check whether the nominal value is correct.</p> <p>On instruments with several channels, press the ESC button and check the nominal value on all other channels.</p> <p>Go back to the C1 menu.</p>	Typically, the nominal value is set to 0.00 E on instruments that measure in absorbance (Meas. channels\Channel n\Lin/Log on Log). The nominal value is set to 100.0 % on instruments that measure in transmittance (Meas. channels\Channel n\Lin/Log on Lin).
	<p>2.4: Press the initiate button. Recalibration of all channels is made simultaneously.</p> <p>If the adjustment was successful, this is confirmed with Adjustment OK. Recalibration is now complete.</p> <p>If the adjustment was not successful, this is indicated with Adjust. fault. In this case, check the points in the following list one after the other:</p> <ul style="list-style-type: none"> ▪ Instrument mounted correctly? ▪ Soiling of the instrument too heavy? ▪ Air bubbles in the measuring cell? ▪ Correct nominal values set? ▪ Correct zero medium used? ▪ Misplaced checking unit, see Section 9.11 	If the check could not be successfully completed, contact your country representative.



9.10 Recalibrating the photometer with sliding measuring cell



Recalibrating the photometer can result in deviations from the previous measuring value as the instrument is newly reset to a reference value (e.g. distilled water).

In order for recalibration with the sliding measuring cell to be carried out, the instrument must be specially configured at the factory. After this configuration has been made, **Calibr. cell** is displayed in the title bar of the **Recalibr./Channel** menu.

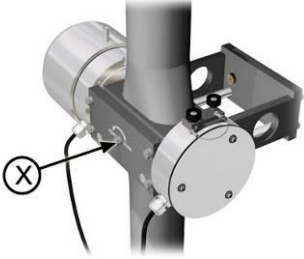

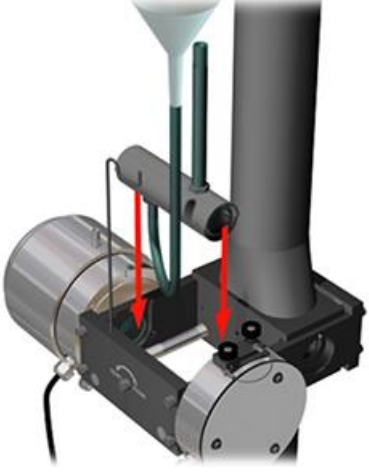
	WORKSTEP	ADDITIONAL INFO / IMAGES
1.	Loosen the lock (X) and slide the measuring cell from the measurement position. 	
2.	Insert the holder for the funnel in the bore (arrow). 	
3.	Insert the calibration measuring cell up to the stop in the guides, then hang the funnel in the holder. 	



	WORKSTEP	ADDITIONAL INFO / IMAGES
4.	<p>Carefully fill zero medium (e.g. distilled water) into the funnel (1) until the fill level display (2) is approximately half full.</p> <p>Pay attention to the attached document on confirming calibration here.</p> <p>i There must be no air bubbles in the measuring cell during recalibration. Careful filling of the sample medium prevents the build-up of bubbles.</p>	
5.	5.1: Press the Menu button.	
	5.2: Set the access code and confirm with OK .	i Factory setting is 0 .
	<p>5.3: Select the Recalibration menu and then press C1. Check whether the nominal value is correct.</p> <p>On instruments with several channels, press the ESC button and check the nominal value on all other channels.</p> <p>Go back to the C1 menu.</p>	<p>i Typically, the nominal value is set to 0.00 E on instruments that measure in absorbance (Meas. channels\Channel n\Lin/Log on Log). The nominal value is set to 100.0 % on instruments that measure in transmittance (Meas. channels\Channel n\Lin/Log on Lin).</p>
<p>5.4: Press the initiate button. Recalibration of all channels is made simultaneously.</p> <p>If the adjustment was successful, this is confirmed with Adjustment OK. Recalibration is now complete.</p> <p>If the adjustment was not successful, this is indicated with Adjust. fault. In this case, check the points in the following list one after the other:</p> <ul style="list-style-type: none"> ▪ Instrument mounted correctly? ▪ Soiling of the instrument too heavy? ▪ Air bubbles in the measuring cell? ▪ Correct nominal values set? ▪ Correct zero medium used? ▪ Misplaced checking unit, see Section 9.11 	<p>i If the check could not be successfully completed, contact your country representative.</p>	
6.	Empty the calibration measuring cell and then remove it.	
7.	Slide the measuring cell back into the measurement position and lock it in place. The instrument can now be operated again.	

9.11 Functional check with checking unit



	WORKSTEP	ADDITIONAL INFO / IMAGES
1.	<p>Fill the measuring cell with a zero medium. Pay attention to the attached document on confirming calibration here.</p> <p>i The measuring cell may only be emptied again after recalibration has been made according to the following point and the value has been read.</p>	<p>i Clean the measuring cell before the functional check, if required.</p> <p>There must be no air bubbles in the measuring cell (low flow, light counter pressure).</p>
2.	<p>Carry out recalibration according to Section 9.9 / Section 9.10(sliding measuring cell).</p>	
3.	<p>Loosen the knurled screws (A) and remove the cover (B).</p>	
4.	<p>Insert the checking unit into the opening (C) and fasten in place with the knurled screw (D).</p>	



	WORKSTEP	ADDITIONAL INFO / IMAGES
5.	<p>The current measuring value on channel 1 is displayed in the Recalibration\C1 menu under Act. val.</p> <p>Depending on the setting in Meas. channels\Channel n\Lin/Log the measuring value is shown in % transmittance (Lin) or in absorbance (Log).</p> <p>Compare the actual value with the value on the checking unit.</p> <p>In the event of a deviation of more than $\pm 2\%$ the measuring value or absolute 0.1%T, repeat steps 1 to 5.</p> <p>If the measured value deviates once again, then contact the service center.</p> <p>On instruments with several channels, press the ESC button and then compare the actual value and nominal value on all other channels.</p> <p>If the measured value matches the value on the housing, then continue from point 6.</p>	
6.	<p>Remove the checking unit and reattach the cover.</p> <p>The instrument can now be operated again.</p>	

9.12 Replacing the UV light source



DANGER!

Danger of injuries on the UV light source caused by electric shocks, UV radiation and high temperatures.

When replacing the UV light source, careless handling can lead to electric shocks, eye injuries caused by UV radiation and burns due to temperatures in excess of 80 °C. It is thus essential to observe the following safety measures when removing the UV light source:



- The service voltage must be interrupted before opening the housing.
- The instrument must not be operated when the housing is removed under any circumstances.
- Before opening, wait until the instrument has cooled down to a manageable temperature.

The following procedure describes how to install and remove the UV light source:



	WORKSTEP	ADDITIONAL INFO / IMAGES
1.	Stop the sample flow and let the measuring cell run dry.	
2.	Interrupt the service voltage.	
3.	Loosen the three hex bolts and remove the housing.	
4.	Remove the plug (B) of the UV light source (A) from the print.	
5.	Loosen the Allen bolt (C) on the UV light source (A).	

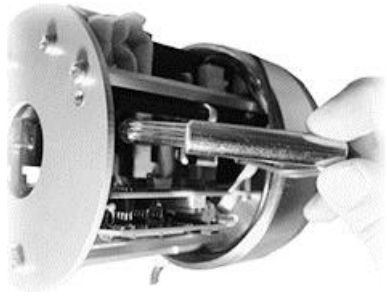

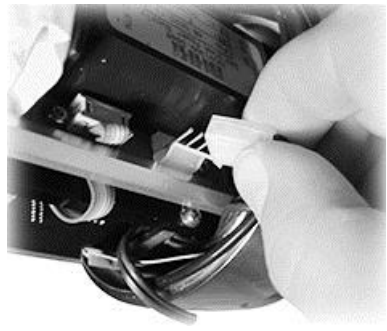
	WORKSTEP	ADDITIONAL INFO / IMAGES
6.	Pull the UV light source from the holder.	
7.	Insert the new UV light source up to the stop in the holder and fasten in place with the Allen bolt. <hr/>  The marking on the light source must match that on the holder.	
8.	Reinsert the plug on the print.	
9.	Replace the desiccant bag according to Section 9.7.	
10.	Reassemble the instrument in reverse order.	
11.	Carry out recalibration according to Section 9.9.	

9.13 Changing the battery in the SICON (M)



DANGER!

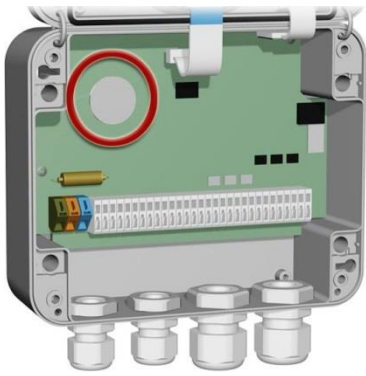

Life-threatening voltage inside the instrument.
 Connecting electrical lines can be extremely dangerous. Instrument parts may also be damaged. Local regulations for electrical installations must be observed at all times.

	WORKSTEP	ADDITIONAL INFO / IMAGES
1.	Interrupt the service voltage to the SICON.	
2.	Open the control unit according to Section 5.2.	
3.	Remove the battery (circle).	
4.	Insert the new battery.	
5.	Close the control unit.	
6.	Re-establish the service voltage.	
7.	Set date and time.	

10 Troubleshooting

10.1 Pinpointing malfunctions

DETECTABLE FAULT	MEASURE
No reading	<ul style="list-style-type: none"> ▪ Check whether the supply voltage is connected. ▪ Check whether the mains plug is connected. ▪ Check whether the instrument is switched on.
Fault message in the display	<ul style="list-style-type: none"> ▪ Analyze the fault message according to Section 10.3.
The reading appears to be wrong	<ul style="list-style-type: none"> ▪ Ensure that the sample to be measured corresponds to the operating conditions (Section 2.9.1/ Section 9.9). ▪ Carry out recalibration (Section 9.10). ▪ Check whether the instrument is correctly mounted (Section 4). ▪ Ensure that the servicing duties have been performed according to the servicing schedule (Section 9.1).



Table 2: Pinpointing malfunctions



If the listed measures do not lead to the desired results, please consult customer service (Section 11).

10.2 Warning messages and effect on operation

Warnings indicate an unusual state.

WARNINGS	
<p>If a warning occurs during operation, it has the following effects:</p> <ul style="list-style-type: none"> ▪ The system continues to operate. However, the measuring results must be evaluated with caution. The cause of the warning message should be remedied at the next possible opportunity. ▪ When the cause of the warning has been remedied, it is automatically deleted. ▪ When the Warning message occurs, the color of the status display changes to orange and the warning text describes the warning in question. 	 <p>Example: WARNING CURRENT 1</p>



The following warning messages can be displayed:

WARNING	DESCRIPTION	POSSIBLE CAUSES
V IN	The input voltage is outside the permitted range (VIS: 9 .. 30 VDC/ UV: 20 .. 26 VDC).	<ul style="list-style-type: none"> ▪ The service voltage is faulty.
ADJUST FAULT	Recalibration could not be carried out.	<ul style="list-style-type: none"> ▪ The instrument is soiled. ▪ The nominal value for the adjustment does not match the value of the medium.
SOILING	The soiling level is greater than the set limit.	<ul style="list-style-type: none"> ▪ The measuring cell is soiled and has to be cleaned.
NEGATIVE VAL	Warning in the event of negative absorbance values. The measuring value is smaller than the set limit.	<ul style="list-style-type: none"> ▪ The last recalibration was incorrect. ▪ Also possible on instruments with soiling compensation in the event of very heavy soiling.
OVER TEMP	The temperature in the instrument has exceeded 65 °C.	<ul style="list-style-type: none"> ▪ The medium or ambient temperature is too high and defective/no cooling.
HUMIDITY	The relative humidity in the instrument has risen above the set limit.	<ul style="list-style-type: none"> ▪ The desiccant is saturated. ▪ The gaskets on the electronics component are defective. ▪ The instrument was open for a long period.
AN.MEAS.FAULT	The measuring value acquisition of the analog channels is disturbed.	<ul style="list-style-type: none"> ▪ Defect in the electronic system. → Service technician

WARNING	DESCRIPTION	POSSIBLE CAUSES
ANALOG IN 1/2	The input signal on analog input 1/2 is less than the error limit.	<ul style="list-style-type: none"> There is no input signal.
CURRENT 1 .. 8	Current output 1 .. 8 is disturbed.	<ul style="list-style-type: none"> Terminals open. Interruption of the current loop of the measuring value output.
TEMP.SENSOR	The inner temperature sensor failed.	<ul style="list-style-type: none"> Defect in the electronic system. → Service technician
EXTERNAL ON (Name ext.in.)	An external event is signaled via a digital input.	<ul style="list-style-type: none"> External malfunction.
SERVICE	Shows when service work is due.	<ul style="list-style-type: none"> Service work is due.
VERS.SD CARD	The data on the microSD card does not match the current software.	<ul style="list-style-type: none"> Update was performed incorrectly.
WATCHDOG	The internal fault monitoring has been actuated. The program has been re-started.	<ul style="list-style-type: none"> Program crash.

Table 3: Possible warning messages

10.3 Fault messages and effect on operation

FAULT	
<p>If a fault occurs during operation, it has the following effects:</p> <ul style="list-style-type: none"> A fault is a malfunction which prevents correct measurement value acquisition. The measuring values of the concerned photometer go to 0. Assigned current outputs go to the programmed electrical current If fault. Assigned limits are deactivated. When the Fault message appears, the color of the status display changes to red and the text describes the fault in question. If an output for faults is programmed, it is activated. 	 <p>Example: FAULT SERIAL 1</p>

The following fault messages can be displayed:

FAULT MESSAGE	DESCRIPTION	POSSIBLE CAUSES
SLAVE SW VERS	The software version of the photometer does not match that of the control unit.	<ul style="list-style-type: none"> ▪ Different delivery data on instrument and control unit. Carry out a slave update. → Reference Handbook
SERIAL 1	The control unit cannot establish a connection to the photometer.	<ul style="list-style-type: none"> ▪ Interrupted connection to the photometer. ▪ Defect in the electronic system. → Service technician
V ANALOG	One of the internal analog voltages is outside the permitted range.	<ul style="list-style-type: none"> ▪ Defect in the electronic system. → Service technician
MEASUR. FAULT	Measuring value acquisition is faulty.	<ul style="list-style-type: none"> ▪ Bubbles in the water. ▪ External light in the vicinity of the measuring point (e.g. transparent hoses). ▪ Defect in the electronic system. → Service technician
LIGHT SOURCE 1 .. 3	The detector for monitoring the light source receives no light from the corresponding light source.	<ul style="list-style-type: none"> ▪ Defective light source. → Service technician
HUMIDITY	The relative humidity in the instrument has risen above 50%.	<ul style="list-style-type: none"> ▪ The desiccant is saturated. ▪ The gaskets on the electronics component are defective. ▪ The instrument was open for a long period.
MASTER SW VERS	This fault message is displayed when the software version of the SICON is older than the version of the connected photometer.	<ul style="list-style-type: none"> ▪ Software is not the most recent version. In this case, the software of the control unit must be updated to the most recent version. → Reference Handbook
POWERBOX	Actuation of the power box has been disturbed.	<ul style="list-style-type: none"> ▪ Connection to the power box has been interrupted.
IO PORT	The connection between NG_Haupt and NG_Bedi-Print in the SICON has been disturbed.	<ul style="list-style-type: none"> ▪ Cable disconnected. ▪ Plug connection defective.

Table 4: Possible fault messages

10.4 Prioritized fault messages and their effect on operation



CAUTION!

When there is a prioritized fault, the cause of the malfunction is serious.



<p>PRIO (PRIORITIZED FAULT)</p> <p>If a prioritized fault occurs during operation, it has the following effects:</p> <ul style="list-style-type: none"> ▪ The measuring values go to 0. ▪ Prioritized faults can be cleared only by a service engineer. ▪ When the Prio message occurs, the color of the status display changes to red and the text describes the prioritized fault in question. 	 <p>Example: PRIO DEFAULT VALUES</p>
--	--

The following prioritized fault messages can be displayed:

PRIO MESSAGE	DESCRIPTION	POSSIBLE CAUSES
DEFAULT VALUES	The default values were loaded.	<ul style="list-style-type: none"> ▪ If no parameters were initialized or if all parameters were lost, the default values are loaded.
CRC EXPERTS	A fault was determined when the expert data was checked.	<ul style="list-style-type: none"> ▪ Electromagnetic malfunctions. ▪ Defect in the electronic system.
CRC USER	A fault was determined when the user data was checked.	<ul style="list-style-type: none"> ▪ Electromagnetic malfunctions. ▪ Defect in the electronic system.
CRC DISPLAY	A fault was determined when the display data was checked.	<ul style="list-style-type: none"> ▪ Electromagnetic malfunctions. ▪ Defect in the electronic system.
EXT RAM	A fault was determined when the RAM in the graphic controller was checked.	<ul style="list-style-type: none"> ▪ Defect in the electronic system.
SW VERS	Software which is unsuitable for this instrument type was loaded.	<ul style="list-style-type: none"> ▪ Faulty software update. → Service technician

Table 5: Possible prioritized fault messages

11 Customer service information

Should you have any questions, please contact the responsible service center in your country or region. If this is not known, SIGRIST-PHOTOMETER AG customer service in Switzerland would be glad to provide you with a contact address.

A current list of all SIGRIST country representatives is available online at www.photometer.com.

Please have the following information ready when you contact a SIGRIST service point or customer service:







- The serial numbers of the connected instruments.
- A description of instrument behavior and the work steps when the problem occurred.
- A description of what you did when trying to solve the problem yourself.
- The documentation of the third-party products you use in conjunction with the ColorPlus 2.
- Description of operation conditions (place, power supply, measured medium, temperature etc.)
- Application and Instruction Manual.

12 Decommissioning/Storage

12.1 Decommissioning the photometer

The aim of decommissioning is to prepare the individual components of the system properly for storage.



	WORKSTEP	ADDITIONAL INFO / IMAGES				
1.	Interrupt the service voltage to the instrument.					
2.	Stop the sample flow and let the measuring cell run empty.					
3.	Remove the electrical connections on the control unit.	Section 5				
4.	<p>Remove cleaning agent connections carefully.</p> <div style="border: 1px solid black; padding: 5px; background-color: #f0f0f0;">  <p>Injuries to the eyes and skin due to the uncontrolled release of cleaning agent into the surrounding area. Non-observance of this warning can lead to permanent damage to the eyes and skin. Adhere to the following instructions:</p> <table border="1" style="width: 100%; border-collapse: collapse;"> <tr> <td style="text-align: center;"></td> <td>Wear protective goggles.</td> </tr> <tr> <td style="text-align: center;"></td> <td>Wear gloves and safety clothing.</td> </tr> </table> </div>		Wear protective goggles.		Wear gloves and safety clothing.	<div style="border: 1px solid black; padding: 5px;"> <p>i Carry out this step only in the case of the 4th clarification stage.</p> </div>
	Wear protective goggles.					
	Wear gloves and safety clothing.					
5.	Remove the control unit and pack for storage.					
6.	Remove the instrument.					
7.	Clean and dry the instrument.					
8.	Clean and dry the measuring cell.					
9.	Close all openings on the photometer.					
10.	Close all openings on the measuring cell.					

12.2 Storing the photometer

There are no special requirements for storing the instruments. However, please note the following information:

- The system contains electronic components. Storage for such components must fulfill the usual conditions. It is important to note that the storage temperature must be between -20 and +50 °C.
- All components that come into contact with the sample during operation have to be dry and clean for a long time before being put into storage.
- The measuring equipment with all of the accessory parts must be protected against weather factors, condensing humidity and aggressive gases during storage.

13 Packaging / Transport / Returning



DANGER!

Injuries to persons due to hazardous media residues in the returned instrument.

Instruments that have come into contact with hazardous media may not be sent without the appropriate information on the corresponding repairs or professional decontamination (see RMA form).

- Precise information on the medium must be received by SIGRIST-PHOTOMETER in advance of the instrument to be repaired so that the necessary precautions can be taken when unpacking it.

The original packaging materials should be used for packaging the ColorPlus 2 if possible. If the original packaging is no longer available, note the following information:

- Before packaging, close the openings of the instrument with adhesive tape or plugs so that no packaging materials can enter the instrument.
- The instrument contains optical and electronic components. Make sure that the packaging protects the instrument from being damaged by impacts during transport.
- All peripheral devices and accessory parts must be packaged separately and marked with the serial number of the photometer (Section 2.7). This prevents confusion and mix-ups later while also making it easier to identify parts.
- A RMA form (14711E) must be filled in and enclosed for all returned instruments and spare parts. This can be downloaded at www.photometer.com.

When packaged as described above, the instruments can be transported via all usual shipping methods.

14 Disposal



Disposal of the system and its peripheral devices is to be carried out in compliance with regional statutory regulations.

The system has no environmentally damaging sources of radiation. The materials listed below should be disposed of or recycled as described in the following table:

CATEGORY	MATERIALS	DISPOSAL POSSIBILITIES
Packaging	Cardboard, wood, paper	Reuse as packaging material, local disposal center, incineration plants
	Protective foils, polystyrene shells	Reuse as packaging material, recycling
Electronics	Circuit boards, electromechanical components, display, touchscreen, transformer and cables	To be disposed of as electronic waste
Parts which come into contact with water	PVC	Local disposal center
	PVDF	Local disposal center
	Stainless steel	Waste metal disposal centers
Optics	Glass, aluminum, brass	Recycling via centers for recycling glass and waste metal
Filter and lens holder	Aluminum	Waste metal disposal center
Battery	Lithium	Recycling via locally organized collection point
UV lamp	Mercury, metal, glass, porcelain	Special waste
Photometer housing	Stainless steel / aluminum	Local disposal center
Desiccant	Rubingel	Normal waste disposal (chemically safe)
Acid tank	PEHD	Special waste
Collecting basin	PELD	Special waste

Table 6: Materials and their disposal

15 Spare parts list

The parts mentioned in this documentation and their article numbers are listed in the following table:

ARTICLE NUMBER	ARTICLE NAME	REMARKS
106743	Instrument cable 5m for WTM500, DualScat, SG, ColorPlus, VisGuard, TurBiScat	
107633	Measuring cell window for KPA & ColorPlus 44 x 3.5, Pos. 6, Tempax	
107717	Measuring cell window for KPA & ColorPlus 44 x 3.5, Pos. 6, Suprasil	
108245	O-ring for cover, EPDM, 1 pc. 120.2 x 3.53	
108740	Housing seal, 119.82 x 3.2, DualScat & ColorPlus	
113294	Leakage protector seal, ColorPlus bypass (O-Ring EPDM 26.65x2.62)	
114083	Enclosure, ColorPlus transmitter & DualScat	
114098	O-Ring FEP/FKM 37.69x3.53 ColorPlus Measuring cell SS	
114854	Cooling transmitter ColorPlus (spare part)	
114900	OPL-bit wrench for ColorPlus(2)	
118273	Hexagon spanner for window screwing (SW32): ColorPlus(2)	
100957	Terminal key	
115663	O-Ring EPDM 5x2.5 70 Shore A, for StackGuard & VisGuard, ColorPlus, DualScat	
117012	Housing screw M4x16 1.4571 with O-Ring	
114679	UV-light source: ColorPlus(2)	
118378	UV-light source phosphor (280nm): Colorplus(2)(Ex)	
117853	Checking unit VIS 1% for ColorPlus	
117854	Checking unit UV 1% for ColorPlus	
117883	O-Ring EPDM 37.69x3.53 for ColorPlus & KPA	
118371	PVC measuring body cell 100 mm with access	Spare part for 118407 and 118404.
118401	Compensation glass VIS for ColorPlus 100 mm with access	Spare part for 118404.

ARTICLE NUMBER	ARTICLE NAME	REMARKS
118403	Compensations glass UV for ColorPlus 100mm with access	Spare part 118407 and 118408.
119058	PVC measuring body cell 50mm with access	Spare part 119065 and 119066
119062	Compensations glass VIS for ColorPlus 50mm with access	Spare part for 119065
119063	Compensations glass UV for ColorPlus 50mm with access	Spare part 119066
111391	Desiccant bar, 30g	
117920	Checking unit VIS 3% for ColorPlus(2)	
117921	Checking unit VIS 10% for ColorPlus(2)	
117922	Checking unit VIS 20% for ColorPlus(2)	
117923	Checking unit VIS 50% for ColorPlus(2)	
117924	Checking unit VIS 80% for ColorPlus(2)	
117925	Checking unit UV 3% for ColorPlus(2)	
117926	Checking unit UV 10% for ColorPlus(2)	
117927	Checking unit UV 20% for ColorPlus(2)	
117928	Checking unit UV 50% for ColorPlus(2)	
117929	Checking unit UV 80% for ColorPlus(2)	
114901	OPL-Bit window borosilicate ColorPlus Inline	
114902	OPL-Bit window quartz ColorPlus Inline	
114903	OPL-Bit window sapphire ColorPlus Inline	
113296	Leakage protector seal, ColorPlus in-line (VITON O-Ring 11.91x2.62)	
114947	1 set EPDM seals for OPL-Bit: ColorPlus(2)	
114948	1 set NBR seals for OPL-Bit: ColorPlus(2)	
114949	1 set FPM seals for OPL-Bit: ColorPlus(2)	
114950	1 set FFPM seals for OPL-Bit: ColorPlus(2)	
115648	Seal Kalrez 28.0x22.0 1.02	
103808	Seal Neopren 28 x 22 x 1	
107154	Tempax glass window 27x6.5	
103832	Slide ring Teflon 27 x 23 x 0.8	
115660	O-Ring FPM 29x1.5 70 Shore A	
116176	O-Ring FPM 22x1.5 75 Shore A	
118363	O-Ring EPDM 67x1.5 70 Shore A	For compensations glass of the 100mm measuring cell

ARTICLE NUMBER	ARTICLE NAME	REMARKS
119064	O-Ring EPDM 35x1.5 70 Shore A	For compensations glass of the 50mm measuring cell
111834	Battery 3V CR 2032 (button battery)	for SICON

16 Index

4

- 4-way current input50
- 4-way current output49

A

- Access code, set72
- Analog modules49

B

- Back-up fuse38
- Battery, SICON95

C

- Cable cross-section41
- Cable ties51
- Calibration measuring cell 14, 19
- Calibration solutions27
- CE mark6
- Checking unit 10, 11, 12, 27
- Chlorine measuring point 12
- Cleaning the compensation glass76
- Commissioning52
- Compensation glass76
- Configuring the current outputs67
- Conformity of the product6
- Connection, mains device51
- Connections, long41
- Cross-section 32, 41
- Current modules49
- Customer service 101

D

- Danger symbols on the instrument28
- Dangers7, 26
- Date and time71
- Decommissioning 102
- Desiccant, receiver87
- Desiccant, transmitter86
- DIL switch42
- Directives6
- Disposal 105
- Distance, max.41
- Documentation, additional5

E

- Electrical installation

- Power 38
- Environmental damage 105
- Ethernet connection 40

F

- Fault 98

G

- Glossary 5

H

- HART 47
- Horizontal 31

I

- Improper use 7
- Initial start-up 52
- Inline housing 31
- Inspection glasses 31
- Installation position 30, 31
- Internet security 29

L

- Language 66
- Log screen 59

M

- Main switch 38
- Mains device 51
- Measurement set-up 32
- Measuring cell window 82, 84
- Modbus RTU 44
- Mounting 30
- Mounting inline version 31
- Mounting the water version 30
- Mounting VARINLINE® version 31

O

- Operation 54
- OPL bit 32
- Overview 10, 11, 12, 13, 14
- Overview 4th clarification stage 15
- Ozone measuring point 11

P

- Parts overview 106

Pictograms	9	Sliding measuring cell.....	82
Pinpointing faults	96	Sliding measuring cell.....	14
Power supply	51	spear parts	106
Prioritized fault messages	100	Storage	5, 103
Products overview	10, 11, 12, 13, 14	T	
Profibus DP	44	Target group of the document	5
Profinet IO	46	Technical data	22, 25
Proper use	6	Terminal block.....	42
Protect, settings	72	Terminal box	41
Protective conductor	38	Terms, glossary.....	5
Purpose of the document.....	5	Touchscreen	54
R		Transport	104
Rating plate	16	Troubleshooting	96
Residual risk	28	U	
S		USB connection	40
Safety symbols	8	Use restrictions.....	6
Save data	73	User requirements	6
Scope of supply.....	17	V	
Scope of supply, optional	18	VARINLINE® housing.....	13
Scope of supply, standard	17	Vertical.....	31
Screen lock	61	W	
SD card adapter	40	Warning symbols on the instrument.....	28
Service center.....	101	Warnings	26, 97
Service mode	62	Water measuring point.....	10
Servicing duties	75	Web user interface	52
Setting the current outputs	67		
Setting the limits	68		
Setting the outputs	70		
SICON (M).....	39, 40, 41		

SIGRIST-PHOTOMETER AG
Hofurlistrasse 1
CH-6373 Ennetbürgen
Switzerland

Tel. +41 41 624 54 54
Fax +41 41 624 54 55
info@photometer.com
www.photometer.com